

**B.L.D.E.A's V.P.Dr.P.G.HALAKATTI COLLEGE OF ENGINEERING
AND TECHNOLOGY VIJYAPUR 586103**

INDEX FILE QUESTION PAPERS JUN/JUL 2023

BACHULER OF ARCHITECTURE

S.N	SUB CODE	SUBJECT CODE	Page No
First SEM			
1	18ENG15	Building Structures-I	2 - 5
Second SEM			
2	21ARC24	History of Architecture-II	6
3	21EGH28	Professional Writing Skills in English	7 -15
Third SEM			
4	21ARC33	Climatology	16- 17
5	21ARC34	History of Architecture-III	18 - 19
6	21ARC35	Building Services-I	20 - 21
7	21ENG36	Building Structures-II	22 -24
Fourth SEM			
8	18ARC42	Materials and Methods in Building Construction- IV	25 - 26
9	18ARC44	History of Architecture-IV	27
10	18ARC44	Building Services-II	28 -29
11	18ARC46	Constitution of Indian and Professional Ethics	30- 35
12	21UH49	Universal Human Values and Professional Ethics	36 - 41
Fifth SEM			
13	18ARC53	Building Services-II	42 - 43
14	18ARC54	History of Architecture-V	44 - 45
Sixth SEM			
15	18ARC62	Materials and Methods in Building Construction- IV	46
16	18ARC63	Building Services-III	48
17	18ARC64	Contemporary Architecture	49
18	18ARC66	Landscape Architecture	50
Seventh SEM			
19	18ARC73	Building Services-IV	51 - 52
20	18ARC74	Specification, Quantity and Costing of Building	53 - 55
21	18ARC75	Urban Design	56 - 57
Eight SEM			
22	18ARC82	Materials and Methods in Building Construction- VIII	58
23	18ARC84	Professional Practice	59
24	18ARC85	Construction and project Management	60 - 61

CBCS SCHEME

USN

--	--	--	--	--	--	--	--	--	--

18ENG15

First Semester B.Arch. Degree Examination, June/July 2023
Building Structures - I

Time: 3 hrs.

Max. Marks: 100

Note: Answer any FIVE full questions, choosing ONE full question from each module.

Module-1

- 1 Explain the properties of the following :
- Concrete
 - Wood
 - Steel
 - Aluminium
 - Glass

(20 Marks)

OR

- 2 a. Define the following :
- Dead load
 - Live load
 - Impact load
 - Earthquake load
 - Static load
- b. Explain load path in a structure with a neat figure.
- c. Write a short note on concrete.

(05 Marks)

(10 Marks)

(05 Marks)

Module-2

- 3 a. What is a force system? Explain the classification of force system (Any 5). (10 Marks)
- b. What is a couple? List the characteristics of a couple. (05 Marks)
- c. Find the resultant of the coplanar concurrent force system shown in the Fig.Q3(c).

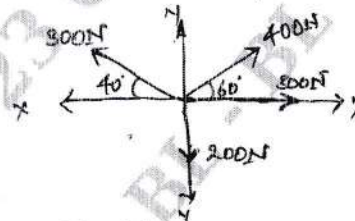

Fig.Q3(c)

(05 Marks)

OR

- 4 a. Define and explain transmissibility of force with neat sketches. (06 Marks)
- b. Define the following :
- Resultant
 - Moment
 - Reaction
 - Equilibrant
- (04 Marks)
- c. Four coplanar forces acting at a point are shown in Fig.Q4(c). One of the force is unknown and its magnitude is shown by P. The resultant has a magnitude of 500 N and is acting along the x-axis. Determine the unknown force P and its inclination with the x-axis. (10 Marks)

Important Note : 1. On completing your answers, compulsorily draw diagonal cross lines on the remaining blank pages.
 2. Any revealing of identification, appeal to evaluator and/or equations written eg. 42+8 = 50, will be treated as malpractice.

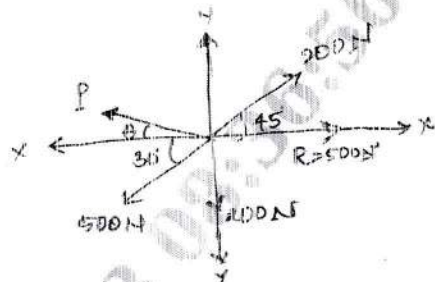

Fig.Q4(c)

Module-3

- 5 a. What are different types of supports? Explain with figure. (08 Marks)
 b. Determine the magnitude, direction of the resultant force for the force system shown in Fig.Q5(b). Also locate the resultant force with respect to point D. (12 Marks)

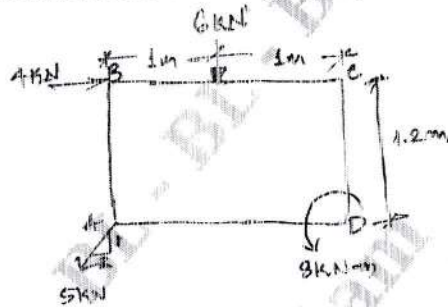

Fig.Q5(b)

(12 Marks)

OR

- 6 a. Explain different types of beams with figure. (10 Marks)
 b. Determine the reactions at A and E for the beam shown in Fig Q6(b). (10 Marks)

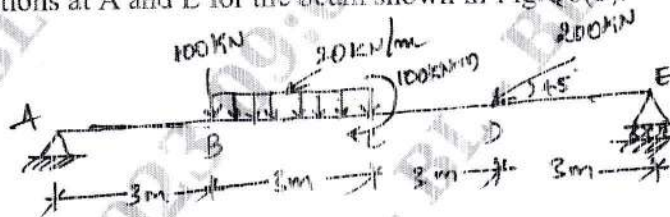

Fig.Q6(b)

(10 Marks)

Module-4

- 7 a. Find the centroid of Fig.Q7(a).

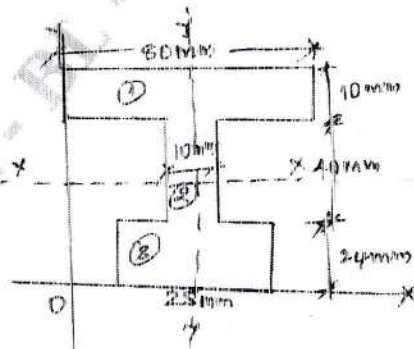

Fig.Q7(a)

(08 Marks)

- b. Determine the moment of inertia about the horizontal axis of the plane lamina shown in Fig.Q7(b). Also find radius of gyration (k) about the horizontal axis.

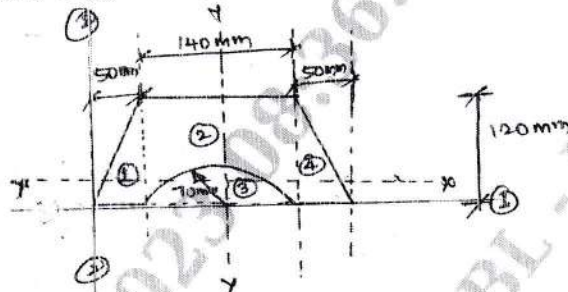

Fig.Q7(b)

(12 Marks)

OR

- 8 a. Define the following :
 i) Centroid
 ii) Centre of Gravity
 iii) Parallel axis theorem with equation
 b. Determine the moment of inertia of the section shown in Fig.Q8(b) about its centroidal axis. Also calculate the least radius of gyration for the section as well.

(05 Marks)

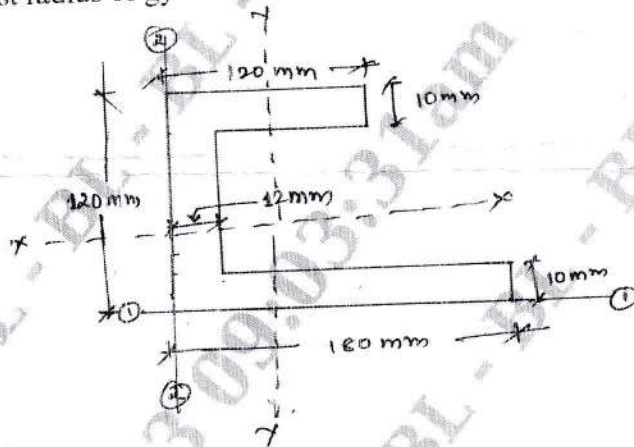

Fig.Q8(b)

(15 Marks)

Module-5

- 9 a. What are the assumptions made in the analysis of truss? (03 Marks)
 b. What are the different types of truss? Explain with figures. (09 Marks)
 c. A truss is shown in Fig.Q9(c), find the support reactions and calculate the total weight if each member has 2 angles 50×50×6 @ 4.5 kg/mt each angle.

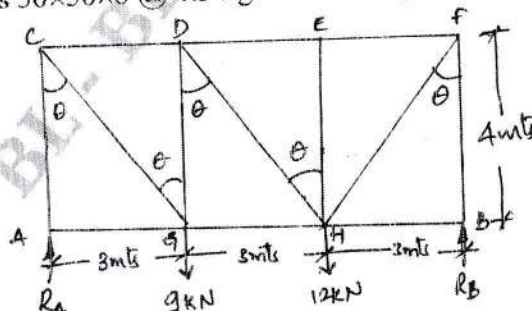

Fig.Q9(c)

(08 Marks)

OR

- 10 Analyse the truss shown in Fig.Q10 by the method of joints. Tabulate the result and indicate the nature of force in the truss.

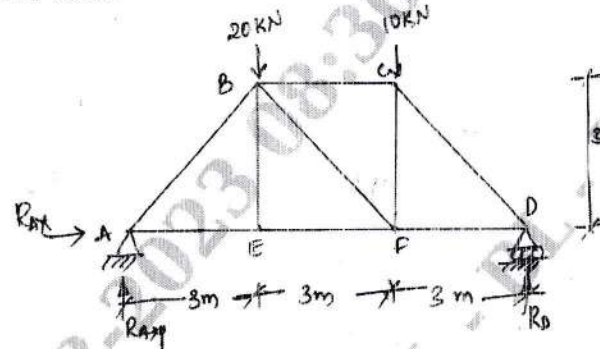

Fig.Q10

(20 Marks)

USN

--	--	--	--	--	--	--	--	--	--

21ARC24

Second Semester B.Arch. Degree Examination, June/July 2023
History of Architecture – II

Time: 3 hrs.

Max. Marks: 100

Note: Answer any FIVE full questions, choosing one full question from each module.

Module-1

- 1 a. Draw and elaborate on significant parts of any Buddhist "Stupa". (10 Marks)
 b. Describe the salient features of a typical "Viharas" with sketches. (10 Marks)

OR

- 2 Elaborate in detail with relevant sketches any one example of distinct Jain temple architecture. (20 Marks)

Module-2

- 3 Illustrate and detail out with labeled sketches the evolution of temple structure of Ladhkhan and Durga temple. (20 Marks)

OR

- 4 Trace the evolution of Hindu temple structure with relevant sketches and structural details. (20 Marks)

Module-3

- 5 Explain the unique features of the following temples:
 a. Brihadeshwara temple
 b. Meenakshi temple. (20 Marks)

OR

- 6 With elaborate details in sketches describe the features:
 a. Gopuram
 b. Vimana
 c. Panchayatana Plan
 d. Antarmala. (20 Marks)

Module-4

- 7 a. Elaborate on the salient features of "Vijaynagar styles temples". (10 Marks)
 b. With details in sketches mention the significant movements of temple complex of Hampi, Karnataka. (10 Marks)

OR

- 8 a. State the unique features of Orissan temple and relate its design to the "Cosmic Man's Body Structure". (12 Marks)
 b. Write a short note on the Lingaraj temple, Bhubaneswar. (08 Marks)

Module-5

- 9 Gujarat style of Architecture is credited for building Surya temple of Modhera and Osian, detail out on both with relevant sketches. (20 Marks)

OR

- 10 Detail out with the help of sketches on the Khajuraho group of temples. (20 Marks)

Important Note : 1. On completing your answers, compulsorily draw diagonal cross lines on the remaining blank pages.
 2. Any revealing of identification, appeal to evaluator and /or equations written eg, 42+8 = 50, will be treated as malpractice.

USN

--	--	--	--	--	--	--	--	--	--

Question Paper Version : D

Second Semester B.Arch./B.Planning Degree Examination, June/July 2023
Professional Writing Skills in English

[Time: 2 hrs.]

[Max. Marks: 100]

INSTRUCTIONS TO THE CANDIDATES

1. Answer all the hundred questions, each question carries one mark.
2. Use only **Black ball point pen** for writing / darkening the circles.
3. **For each question, after selecting your answer, darken the appropriate circle corresponding to the same question number on the OMR sheet.**
4. Darkening two circles for the same question makes the answer invalid.
5. **Damaging/overwriting, using whiteners** on the **OMR** sheets are strictly prohibited.

-
1. **Choose the correct statement :**
a) Kunal has been absent for five days. b) Kunal has been absent since five days.
c) Kunal has been absent from five days. d) Kunal has been absent till five days.
 2. **Correct the incorrect statement :** I've got nobody to talk
a) I've got nobody to talk to. b) I've got nobody to talk with.
c) I've got nobody to talk from. d) I've got nobody to talk into.
 3. Which of these statements belong to present continuous tense (plural)?
a) We are writing a letter. b) She is writing a letter
c) They were writing a letter d) We were writing a letter
 4. To which of these tenses does the following statement belong?
We were watching television all day
a) Simple past tense b) Past continuous tense
c) Past perfect tense d) Past perfect continuous tense
 5. **Fill in with past perfect tense :** I _____ my homework when my uncle arrived.
a) completed b) had completed c) was completing d) had been completing
 6. Which of these is an example of simple present tense?
a) I am going to Delhi tomorrow b) There she goes !
c) He has just gone out. d) I am reading the Gita.
 7. Which of these words is correct?
a) Bureau b) Beaurau c) Bereau d) Bureu

8. **Fill in the blank :** My watch is five minutes _____
 a) behind b) before c) slow d) early
9. **Choose the correct statement :**
 a) It is dirty, throw it b) It is dirty, throw it away
 c) It is dirty, give it d) It is dirty, give it away.
10. **Fill in the blank :**
 I _____ down for an hour every afternoon
 a) lay b) lie c) laid d) lye
11. **Choose the correct statement :**
 a) He tore the letter in anger. b) He tore up the letter in anger.
 c) He teared the letter in anger. d) He teared up the letter in anger.
12. **Fill in the blank :** The thief has _____ all my belongings.
 a) robbed b) taken c) stolen d) taken away
13. Which of these explains a subject?
 a) Narrative essays b) Expository essays
 c) Argumentative essays d) Reflective essays
14. Which kind of essay uses the five senses (touch , smell , taste , sound , sight) to enhance the imagery of the setting?
 a) Narrative essays b) Descriptive essays
 c) Expository essays d) Argumentative essays
15. **Convert the following direct speech to indirect speech :**
 She said, "We will analyse this tomorrow".
 a) She said that they would analyse it the next day.
 b) She said that we would analyse it the next day.
 c) She said that they will analyse it the next day.
 d) She said that we will analyse it the next day.
16. **Convert the following direct speech to indirect :**
 She said, "Thank you !"
 a) She thanked me b) She said me thank you
 c) She said thank you to me d) She said thank you.
17. **Convert the following sentence in direct speech to indirect speech :**
 She said, "Can you read?" and I said "yes".
 a) She asked me can you read and I said yes
 b) She asked me if I could read and I said that I could.
 c) She asked me can you read and I said that I could.
 d) She asked me if I could read and I said yes.
18. **Convert the following active form to passive form :**
 I was determined to mortgage the car.
 a) I was determined that the car should be mortgaged.
 b) The car was determined to be mortgaged.
 c) I was determined that car will be mortgaged.
 d) I am determined that car will be mortgaged.

19. Which of these is not an use of the passive voice?
 a) When we know about the doer of the action
 b) When the subject of the active verb would be people.
 c) To avoid awkward of ungrammatical sentences.
 d) When an active form would create problems for the speaker.
20. Which of these is not a part of speech?
 a) Noun b) Verb c) Preposition d) Object
21. **In the following sentence, replace the verb by a noun :**
 He fought bravely.
 a) He put up a brave fight b) A fight was put up bravely
 c) A brave fight was put up d) A fight is put up bravely.
22. **In the following sentence, replace the adverb with a noun :**
 He watched the girl carefully.
 a) He watched her with care b) He watched the girl with great care
 c) With care he watched her. d) Care was taken while watching her.
23. Which of these must be avoided in business letters?
 a) Polite words b) Formal words c) Abbreviations d) Clear details
24. Which of these must not be mentioned in a business letter?
 a) Information of the quality of the order b) Name of the firm
 c) The mode of payment d) With regards
25. Where should the name of the firm be mentioned?
 a) Right of the page b) Below the address of the writer
 c) Above the address of the writer d) On the last page of the letter
26. Which of these is not a mode of address for any letter?
 a) To a tradesman b) To a child c) To a firm d) To professional men
27. Which of these is not used to conclude a business letter?
 a) Yours faithfully b) Yours truly c) Yours sincerely d) With kind regards
- Choose the appropriate answers :**
28. Which of these reports is written before starting a new project?
 a) Feasibility report b) Periodic report c) Trouble report d) Progress report
29. Which of these reports lists down precautions?
 a) Progress report b) Periodic report c) Trouble report d) Feasibility report
30. In which of these cases is the letter form of report not used?
 a) When reader is a close associate b) When subject matter is brief
 c) When there is breakdown of machinery
 d) When subject matter pertains to a few topics
31. Where is the signature mentioned in a memorandum?
 a) Top left b) Top right c) Bottom left d) Bottom right

32. Interviews are conversations with _____
a) fun b) purpose c) friendliness d) informality
33. Which kind of interview includes a process in which the employability of the job applicant is evaluated?
a) Stress interview b) Screening interview
c) Group interview d) Behavioural interview
34. How many styles are used in a screening interview?
a) Two b) Five c) Three d) Four
35. In which of these interviews, insults are common?
a) Screening interview b) Stress interview
c) Behavioural interview d) Group interview
36. Which of these interviews is adapted for computer programmers?
a) The stress interview b) The group interview
c) The screening interview d) The audition
37. In which of these, more than one candidate is interviewed?
a) The Behavioural interview b) The Stress interview
c) The group interview d) The audition
38. Which of these interviews is taken for a candidate far away?
a) Lunch interview b) Telephone c) Stress interview d) Group interview
39. Which of these is not a part of a proposal?
a) First page b) Outline c) Complaint d) Contents
40. Which of these does the title and first page not includes?
a) Brief information of the proposal b) Name of the institution
c) Nationality of the person submitting the proposal
d) Name of the person submitting the proposal.
41. Which of these is the most important part of the proposal?
a) Title and first page b) Abstract c) Contents d) Experience
42. Where is the proforma placed in a proposal?
a) After title b) After contents c) After introduction d) After outline
43. **Fill in the blank** : Neither he nor I _____ present.
a) were b) was c) are d) am
44. **Correct the statement** :
Your best bet are free tickets.
a) Your best bet is free tickets b) Your best bet were free tickets
c) Your best bet am free tickets d) Your best bet seems free tickets.
45. **Choose the correct statement** :
a) The fire caused many damages b) The fire caused much damage
c) The fire caused many damage d) The fire caused much damages

46. **Fill in the blank** : The ship _____ set sail
 a) has b) is c) was d) have
47. **Correct the statement** :
 Bread and butter are my favourite breakfast
 a) Bread and butter is my favourite breakfast.
 b) Bread and butters are my favourite breakfast.
 c) Breads and butters are my favourite breakfast.
 d) Breads and butter are my favourite breakfast.
48. **Fill in the blank** : None of the students _____ happy with the teacher.
 a) were b) was c) have d) has
49. **Fill in the blank** : bismillah Khan plays _____ shehnai with great skill.
 a) a b) an c) the d) a or the
50. **Correct the incorrect statement** :
 How gentle person Mr. Bhatia is!
 a) How gentle a person Mr. Bhatia is! b) How gentle the person Mr. Bhatia is!
 c) How gentle person the Mr. Bhatia is! d) How a sgentle person Mr. Bhatia is!
51. **Fill in the blank** : Neha has left for _____ United States of America.
 a) a b) the c) an d) to
52. **Fill in the blank** : He lives _____ Bezonbagh _____ Nagpur
 a) in , at b) at , in c) at , on d) on , at
53. **Fill in the blank** : The cat sprang _____ me
 a) on b) upon c) in d) at
54. **Choose the correct statement** :
 a) She walked till the end of the road b) She walked to the end of the road
 c) She walked at the end of the road d) She walked on the end of the road
55. **Fill in the blank** : The factory began production _____ 22nd July.
 a) since b) from c) by d) at
- Find out whether there is any grammatical error in below sentence :**
56. If you cannot / sympathy with the poor , / how will you be / able todo social work?
 a) If you cannot b) sympathy with the poor
 c) how will you be d) able to do social work?
57. On resuming his duty, / he asked his superiors / that whether he would be / permitted to leave early.
 a) On resuming his duty b) he asked his superiors
 c) that whether he would be d) permitted to leave early
58. What is needed today is / a new breed of managers / with a new set of concepts / and a flexible way about thinking.
 a) What is needed today is b) a new breed of managers
 c) with a new set of concepts d) and a flexible way about thinking

59. The basket of apples / sent by the gardener / contained a number of / green mangoes also.
a) The basket of apples b) sent by the gardener
c) contained a number of d) No error
60. This is one of / the most interesting book / I have / ever read.
a) This is one of b) the most interesting book
c) I have d) ever read
61. He was very disappointed / when he found / that someone else / had secured higher marks.
a) He was very disappointed b) when he found
c) that someone else d) No error
62. Every statement must have a subject and a _____
a) noun b) verb c) predicate d) phrase
63. **Choose the correct statement :**
a) Do not make friend with selfish people b) Do not make friendship with selfish people
c) Do not make friends with selfish people d) Do not make friendly with selfish people
64. **Choose the correct statement :**
a) She doesn't know the reason for his disappearance.
b) She doesn't know the reason of his disappearance.
c) She doesn't know the reason at his disappearance.
d) She doesn't know the reason with his disappearance.
65. Some students are _____ at copying.
a) adapt b) adept c) adopt d) edept
66. Father _____ me not to go out in the cold.
a) adviced b) advised c) advice d) advise
67. Which of these should be avoided in the message of a speech?
a) Clarity b) Confusion c) Voice Modulation d) Politeness
68. Which of these is the most important element of the speech process?
a) Message b) Audience c) Feedback d) Speech style
69. Which of these factors need not be considered while preparing speech for the audience?
a) Number of people b) Age of audience
c) Appearance of audience d) Nature of pupose
70. Which of these means to omit?
a) Accept b) Except c) Acept d) Except
71. Which of these means to influence?
a) Affect b) Efect c) Effect d) Affecct
72. _____ is the most important city of a Country.
a) Capitol b) Capetol c) Capital d) Capitalisation

73. Which of these is an adjective?
 a) Course b) Coourse c) Caorse d) Coarse
74. **Fill in the blank.**
 She writes everyday in her ____
 a) dairy b) diary c) deary d) diery
75. Which of these expresses distance?
 a) Farther b) Father c) Further d) Ferther
76. _____ refers to the second – mentioned thing of two things.
 a) Later b) Latter c) Latte d) Late
77. Which of these is a conjunction?
 a) Weather b) Peace c) Piece d) Whether
78. Which of these means a piece of wood?
 a) Wage b) Wadge c) Wedge d) Wedje
79. What is a participle called when it is used as a simple qualifying adjective in front of a noun?
 a) Past participle b) Participial adjective
 c) Participial noun d) Participial adverb
80. **Fill in the blank with present participle :**
 I met a boy _____ a box of chocolates.
 a) carried b) carrying c) was carrying d) had carrying
81. **Pick out the participle in the following sentence :**
 Knowing his aptitude, he should have scored more runs.
 a) Knowing b) Aptitude c) Scored d) Runs
82. **Fill in the blank with past participle :**
 _____ by hate, he lashed out with a knife.
 a) Blinding b) Blinded c) Blind d) Having blind
83. Words of same sound is?
 a) Soundnoms b) Antonyms c) Homonyms d) None of these
84. Sounding the same but spelt differently?
 a) Symphonious b) Homophonous c) Synonyms d) Saminymous
85. We _____ at the party.
 a) Enjoyed ourself b) Enjoyed ourselves
 c) Played with d) None of these.

General English Questions on Pronoun Correction :

86. **Correct the sentence if necessary.**
 One should respect his elders.
 a) One should respect his elders b) One should respect her elders

87. **Correct the sentence if necessary.**
One should respect his own Country.
a) One should respect his own Country. b) One should respect her own Country.
c) One should respect their own Country d) One should respect one's own Country.
88. **Correct the sentence if necessary.**
One must love his parents.
a) One must love her parents. b) One must love his parents.
c) One must love their parents d) One must love one's parents.
89. **Correct the sentence if necessary.** I and Jimmy went home.
a) I and Jimmy went home b) Jimmy and I went home.
c) A and B d) None of the above
90. **Correct the sentence if necessary.**
I and she are friends.
a) I and she are friends b) She and I are friends
c) She and me are friends d) None of the above
91. **Correct the sentence if necessary.**
I and Dhoni went to College
a) I and Dhoni went to College b) Dhoni and I went to College
c) Dhoni and me went to College d) None of the above
92. **Correct the sentence if necessary.**
Both he and you must attend the meeting.
a) Both he and you must attend the meeting b) Both you and he must attend the meeting
c) A and B d) None of the above
93. **Correct the sentence if necessary.**
Peter invited me and you to dinner.
a) Peter invited you and me to dinner. b) Peter invited me and you to dinner
c) A and B d) None of the above
94. **Correct the sentence if necessary.**
I, you and she can do it.
a) I, you and she can do it b) You, I and she can do it
c) You, she and I can do it d) She, you and I can do it
95. **Correct the sentence if necessary.**
None of the three questions are simple.
a) None of the three questions are simple b) None of the three questions is simple
c) A and B d) None of the above.

Sentence Arrangement Questions :

96. All religions are : (P) to advance the cause of peace (Q) in a holy partnership (R) justice and freedom (S) bound together.
a) PQRS b) PRQS c) SPQR d) SQPR

97. A. Totally personal agenda will never bring about this level of fulfillment because that has to result from integration - and not be a substitute for it.
 B. One's consciousness then becomes centred in the identity of the soul.
 C. Realising ourselves and our potential entails becoming a pure reflection and manifestation of the inner self.
 D. Since the soul lives by different laws and values, there is a fundamental conflict in human nature that must be resolved if integration and fulfillment is to be complete.
 a) DCAB b) ABCD c) CBDA d) CABD
98. A. Providing benefits for women and children is a societal responsibility which can be funded in a large country through a combination of general taxation and contributory payments.
 B. This should further lead to close scrutiny of the difficulties faced by unorganized workers who fall beyond the scope of any worthwhile labour welfare measures.
 C. The enhancement of paid maternity leave for women in the organized sector to 26 weeks from 12 is a progressive step.
 D. The reported move to restrict even this meager benefit to the first child for budgetary reasons is retrograde and must be given up.
 E. Positive though it is, the amended law is expected to cover only 1.8 million women, a small subset of women in the workforce.
 Which of the following would be the SECOND sentence after rearrangement?
 a) F b) A c) E d) B
99. A. One evidence of this is that many highly intelligent people are very low on creativity.
 B. In other words they may find replicating a process very easy but creating a process difficult.
 C. But it is unfortunate that in many organisations these replicates are rated high and promoted over creators.
 D. Intelligence and creativity are two different things.
 E. They may understand the things very fast but are poor if any new thing is to be developed; this in long term gives creators an upper edge.
 Which of the following will be the SECOND sentence?
 a) A b) B c) C d) D
100. In the following question, a disarranged sentence is given in which words or phrases are lettered P, Q, R, S... You have to arrange these to form a meaningful sentence.
 P : tramp Q : I was R : as free S : as a
 a) QRSP b) QPRS c) PQRS d) PRSQ

USN

--	--	--	--	--	--	--	--	--	--

21ARC33

Third Semester B.Arch. Degree Examination, June/July 2023

Climatology

Time: 3 hrs.

Max. Marks: 100

Note: Answer any FIVE full questions, choosing ONE full question from each module.

Module-1

- 1 a. Enlist the elements that constitute climate and mention their tools. Elaborate on any one of the element in detail. (10 Marks)
- b. Highlight the interrelation between human built environment and the natural environment with respect to architectural interventions. (10 Marks)

OR

- 2 a. Enlist the thermal indices. Explain Bioclimatic chart in detail with the help of a diagram and state its use. (10 Marks)
- b. Highlight the climate crisis faced over time along with the impact and responsibility now upon the profession of Architecture. (10 Marks)

Module-2

- 3 Explain thermal exchange between a building with outdoor environment. (20 Marks)

OR

- 4 a. Explain Sunpath diagram components with an illustration and state its use. (10 Marks)
- b. Elaborate the steps required to design a shading device on a wall. (Consider a certain wall orientation) (10 Marks)

Module-3

- 5 a. Explain periodic heat flow with regards to time lag and decrement factor. Draw all necessary illustrations. (12 Marks)
- b. Write short notes on : (08 Marks)
 - (i) U value.
 - (ii) Conductance

OR

- 6 a. Calculate U value of a composite west wall. The wall assembly and wall exposure are to be assumed and the steps to be illustrated without actual calculations. (12 Marks)
- b. Write short notes on : (08 Marks)
 - (i) Earth tunnels
 - (ii) Trouble wall

Module-4

- 7 a. Explain the different types of shading devices used in buildings with detailed illustrations. (12 Marks)
- b. Elaborate the functions of natural ventilation and air movement. (08 Marks)

Important Note : 1. On completing your answers, compulsorily draw diagonal cross lines on the remaining blank pages.
2. Any revealing of identification, appeal to evaluator and /or equations written eg. 42+8 = 50, will be treated as malpractice.

OR

- 8 a. Explain the effect of openings on airflow with respect to their positioning, sizes and details. (10 Marks)
- b. Write short notes on : (10 Marks)
- (i) Wind catchers.
 - (ii) Cross ventilation

Module-5

- 9 a. With neat sketches, explain design considerations for warm and humid climate for a residence. (12 Marks)
- b. Write short notes on: (08 Marks)
- (i) Glare control.
 - (ii) Daylight factor.

OR

- 10 a. Explain how to design a climate responsive office building for hot and dry climate. (12 Marks)
- b. Explain daylight factor and its components and its use in architectural spaces. (08 Marks)

CBCS SCHEME

USN

--	--	--	--	--	--	--	--	--	--

21ARC34

Third Semester B.Arch. Degree Examination, June/July 2023 History of Architecture - III

Time: 3 hrs.

Max. Marks: 100

Note: Answer any FIVE full questions, choosing ONE full question from each module.

Module-1

- 1 a. Elaborate on the emergence of Islamic Architecture in 11th century in India. Give the General characteristics of the Indian Islamic style, taking example of the Qutub Minar at Delhi. (10 Marks)
- b. Sketch the layout plan of Quuroat-ul-Islam mosque, Old Delhi and explain the arrangement of various structures and enlargement. (10 Marks)

OR

- 2 a. With the help of neat sketches, explain and highlight the antique features of Khiski Masjid, in terms of planning and aesthetics. (10 Marks)
- b. Explain the planning of an Islamic city, taking Feroz Shah Kotla, as an example. (10 Marks)

Module-2

- 3 a. Comment on the architectural features of the provincial style at Jaunpur. Also elaborate on the architecture of Atala Masjid with detailed sketches. (10 Marks)
- b. Explain with neat sketches, the Golgumbaz at Bijapur. (10 Marks)

OR

- 4 a. Write notes on : (any 2)
- (i) Adina Masjid, Pandua. (10 Marks)
- (ii) Bara Shona Masjid. (10 Marks)
- (iii) Ibrahim Rauza, Bijapur. (10 Marks)
- b. Explain the purpose and architectural features of Vars in Gujarat, with examples of Adalaj ni_var and Rani_ni_Var of Gujarat. (10 Marks)

Module-3

- 5 a. Discuss the principles of planning used in Fatehpur Sikri. Explain any one structure in detail, with neat sketches. (10 Marks)
- b. Explain the unique features of Jama Masjid at Gulbarga. (10 Marks)

OR

- 6 a. Write notes on (any 2) :
- (i) The architecture of Madarassa of Mond, Gawan. (10 Marks)
- (ii) Buland Darwaza. (10 Marks)
- (iii) Tomb of Salim Chisti. (10 Marks)
- b. Explain the concept of "Char-Bagh" with the help of Humayun's tomb. (10 Marks)

Module-4

- 7 a. Taj Mahal, Agra is considered a complete architectural experience. Justify this statement by discussing features of the same. (10 Marks)
- b. What are the features of the early Celomial architecture of the Indian Subcontinent? (10 Marks)

Important Note : 1. On completing your answers, compulsorily draw diagonal cross lines on the remaining blank pages.
2. Any revealing of identification, appeal to evaluator and /or equations written eg, 42+8 = 50, will be treated as malpractice.

OR

- 8 a. Write notes on (any 2) :
- Mughal gardens.
 - Tomb of Itmad_ud_daula.
 - Serzi_Travel shelters.
- b. Explain the characteristics of early British forts in Indian Subcontinent. (10 Marks)

(10 Marks)

Module-5

- 9 a. With suitable examples, explain the design approach and due consideration taken by the British Architects, While designing the Rashtrapati Bhavan, New Delhi. (10 Marks)
- b. Write notes on (any 2) :
- Victoria Terminus (CSMT) Mumbai.
 - SE Cathedral, Goa.
 - Mysore palace and Vicinty

(10 Marks)

OR

- 10 a. Explain the Colonial architecture of India by taking example of the administrative buildings, Railway station of Mysore or Mumbai (SMT). (05 Marks)
- b. Describe the layout and architectural features of Lutyen's Delhi. (05 Marks)
- c. With suitable examples and sketches, explain the architectural design features of a typical French house of Pondi cherry. (10 Marks)

CBCS SCHEME

21ARC35

USN

--	--	--	--	--	--	--	--	--	--

Third Semester B.Arch. Degree Examination, June/July 2023 Building Services – I

Time: 3 hrs.

Max. Marks: 100

- Note: 1. Answer any FIVE full questions, choosing one full question from each module.
2. Sketches shall be written wherever required.*

Module-1

- 1 a. How is water borne diseases caused? Explain. (06 Marks)
b. What is Hygiene? Discuss personal hygiene. (04 Marks)
c. Explain the points of importance in any water supply scheme. (10 Marks)

OR

- 2 Explain with the help of a bubble diagram the process of Water Purification. (20 Marks)

Module-2

- 3 Distinguish between:
i) Inspection chamber and Manhole (with neat sketches)
ii) Gully trap and Bottle trap. (20 Marks)

OR

- 4 a. With help of neat sketch, explain the working of septic tank. (10 Marks)
b. What is rain water harvesting in a domestic house? (10 Marks)

Module-3

- 5 a. Mention the principles of house drainage. (08 Marks)
b. With neat sketches explain
i) Single stack system
ii) One pipe system partially ventilated
iii) Two pipe system. (12 Marks)

OR

- 6 a. With help of neat sketch briefly explain:
i) Tap and mixer
ii) Indian water closet, European water closet.
iii) Flush tank and Flush valve (12 Marks)
b. Explain Air relief valve and pressure relief valve. (08 Marks)

Module-4

- 7 a. What is Solid Waste Management? List the various sources from where the waste is generated. (13 Marks)
b. What is Wormi composting explain. (07 Marks)

Important Note : 1. On completing your answers, compulsorily draw diagonal cross lines on the remaining blank pages.
2. Any revealing of identification, appeal to evaluator and /or equations written eg. 42+8 = 50, will be treated as malpractice.

OR

- 8 a. With help of neat sketch explain working of oxidation pond. (10 Marks)
b. Indicate the standard heights from the finished floor level for the following fixtures with sketches:
i) Wash basin
ii) EWC
iii) Hot and Cold diverter
iv) Shower unit
v) Geyer. (10 Marks)

Module-5

- 9 Draw a schematic fire escape staircase and list mandatory dimensions to
i) Riser
ii) Tread
iii) Landing
iv) Headroom
v) Staircase railing. (20 Marks)

OR

- 10 a. List class of fire extinguishers for various fire hazards. (10 Marks)
b. Explain the use and importance of
i) Fire alavaen
ii) Wet riser in fire safety. (10 Marks)

CBCS SCHEME

USN

--	--	--	--	--	--	--	--	--	--

21ENG36/21ARC36

Third Semester B. Arch. Degree Examination, June/July 2023 Building Structures – II

Time: 3 hrs.

Max. Marks: 100

Note: Answer any FIVE full questions, choosing ONE full question from each module.

Module-1

- 1 a. Draw stress strain curve for mild steel subjected to axial tension and explain all the salient points. (08 Marks)
- b. The following data refer to mild steel specimen tested in tension. Diameter of specimen = 25mm, initial gauge length 300mm, final gauge length 360mm, extension observed under a load of 20kN is 0.060mm, yield load 150kN, load at failure 252kN neck diameter at failure 18.25mm. Determine: i) Young's modulus ii) Yield stress iii) Nominal ultimate stress iv) Actual ultimate stress v) Percentage elongation vi) percentage reduction in area. (12 Marks)

OR

- 2 a. Briefly explain the principle of superposition. (04 Marks)
- b. Write an expression each for elongation of uniformly varying rectangular bar with constant thickness and of uniformly varying circular bar subjected to axial tension. (06 Marks)
- c. A stepped bar with 3 different portion has fixed support at one of its ends. The stepped bar is subjected to forces as shown in Fig Q2(c). Determine the stresses and deformation induced in each portion. Also find the net deformation induced in the stepped bar. Take $E = 200 \text{ GPa}$.

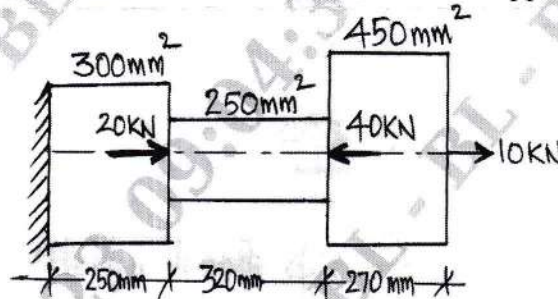

Fig Q2(c)

(10 Marks)

Module-2

- 3 a. Define and explain longitudinal strain, lateral strain and volumetric strain. (08 Marks)
- b. A load of 300kN is applied on a short column 250mm × 250mm. The column is reinforced by steel bars of total area 5600mm². If $E_s = 15E_c$, find the stresses in steel and concrete. If the stress in concrete should not exceed 4N/mm², find the area of steel required so that the column may support a load of 600kN. (12 Marks)

OR

- 4 a. Define Elastic constants. (08 Marks)
- b. A 500mm long bar has rectangular cross section 20mm × 40mm. This bar is subjected to
- 40kN tensile force on 20mm × 40mm face
 - 200kN compressive force on 20mm × 500mm face
 - 300kN tensile force on 40mm × 500mm face

Find the change in volume if $E = 2 \times 10^5 \text{ N/mm}^2$ and $\mu = 0.3$.

(12 Marks)

Module-3

- 5 a. Define effective length of column and give the effective length of the column with different end conditions. (10 Marks)
- b. A solid round bar 3m long and 50mm in diameter is used as steel strut and $E = 2 \times 10^5 \text{N/mm}^2$. Determine crippling load when
- Both end are hinged
 - One end fixed and other end free
 - Both ends fixed.
- (10 Marks)

OR

- 6 a. Explain the limitation of Euler's theory. (06 Marks)
- b. Determine crippling load for an I-section with $400 \times 200 \times 10\text{mm}$ size having length of 6m used as a strut with both ends fixed. $E = 2.1 \times 10^5 \text{N/mm}^2$ F.S = 3. (14 Marks)

Module-4

- 7 a. Define : i) Shear force ii) Bending moment iii) Shear force diagram iv) Bending moment diagram v) Point of contra flexure (10 Marks)
- b. Draw SFD and BMD for simply supported beam shown in Fig Q7(b)

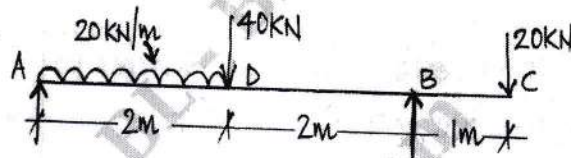

Fig Q7(b)

(10 Marks)

OR

- 8 Draw SFD and BMD for beam shown in Fig Q8 and mark the salient points. Find the point of contraflexure and maximum bending moment.

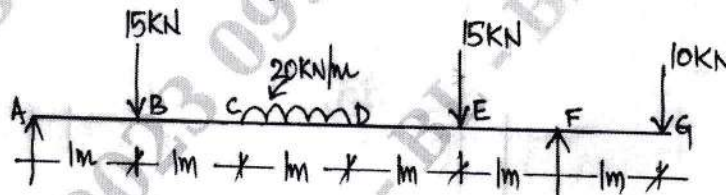

Fig Q8

(20 Marks)

Module-5

- 9 a. Write the bending equation for the beams and expand each of the notations. (08 Marks)
- b. Calculate and draw the bending stress variation for a beam section shown in Fig Q9(b).

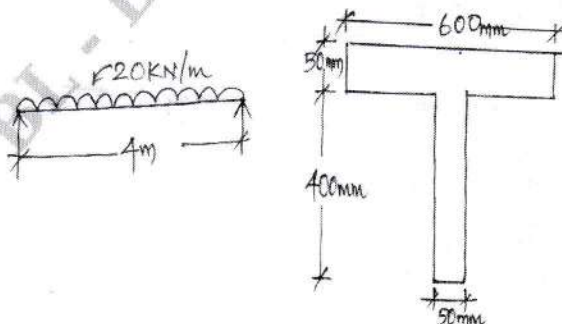

Fig Q9(b)

2 of 3

(12 Marks)

OR

- 10 a. Write the section modulus with neat sketches for i) Rectangle ii) Hollow rectangle
iii) Circle iv) Hollow circle. (08 Marks)
- b. Draw the shear stress variation diagram across the depth for a beam section shown in Fig Q10(b), if the shear force at section is 60kN.

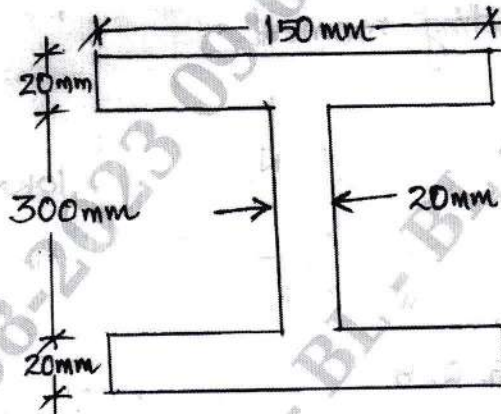

Fig Q10(b)

(12 Marks)

CBCS SCHEME

USN

--	--	--	--	--	--	--	--	--	--

18ARC42

Fourth Semester B.Arch. Degree Examination, June/July 2023**Materials and Methods in Building Construction – IV**

Time: 4 hrs.

Max. Marks: 100

*Note: Answer any FIVE full questions, choosing ONE full question from each module.***Module-1**

- 1 a. Explain in detail different types of flat slab. (10 Marks)
 b. Explain with sketches difference between flat slab and conventional slab beam system. (10 Marks)

OR

- 2 Draw following details of a flat slab with drop panel of span 20 m × 16 m.
 a. Plan (08 Marks)
 b. Section (06 Marks)
 c. Any two detail (06 Marks)
 Assume suitable scale

Module-2

- 3 Design a Mangalore Tile Filler slab for a residence. Draw following details.
 a. Plan (10 Marks)
 b. Section (06 Marks)
 c. Detail (any 1) (04 Marks)
 Assume suitable scale.

OR

- 4 a. Explain with sketches RCC Waffle slab. (10 Marks)
 b. Explain with sketches RCC Filler slab. (10 Marks)

Module-3

- 5 Explain the different types of steel sections used in the construction with its uses and properties. (20 Marks)

OR

- 6 Sketch the following junction details of structural steel sections.
 a. Column to beam junction (10 Marks)
 b. Beam to beam junction (10 Marks)

Module-4

- 7 Draw steel window of size 1m × 1.35 m showing following details.
 a. Plan (06 Marks)
 b. Elevation (06 Marks)
 c. Section (06 Marks)
 d. Any one detail (02 Marks)
 Assume suitable scale.

Important Note : 1. On completing your answers, compulsorily draw diagonal cross lines on the remaining blank pages.
 2. Any revealing of identification, appeal to evaluator and/or equations written eg, 42+8 = 50, will be treated as malpractice.

OR

- 8 Explain the following with neat sketches.
- a. Collapsible gate (10 Marks)
 - b. Rolling shutters (10 Marks)

Module-5

- 9 Draw aluminium sliding window of size 1m × 1.35m showing following details.
- a. Plan (06 Marks)
 - b. Elevation (06 Marks)
 - c. Section (06 Marks)
 - d. Any one detail. (02 Marks)

OR

- 10 Draw plan, elevation, section with joinery detail of aluminium partition of size 6m × 3m (height). (20 Marks)

CBCS SCHEME

USN

--	--	--	--	--	--	--	--	--	--

18ARC44

Fourth Semester B.Arch. Degree Examination, June/July 2023 History of Architecture – IV

Time: 3 hrs.

Max. Marks: 100

Note: Answer any FIVE full questions, choosing one full question from each module.

Module-1

- 1 Elaborate on the architectural characteristics of Stupa at Sanchi. Explain Jocana's in detail. (20 Marks)

OR

- 2 a. Given an example of rock cut caves during the Jain period and explain. (12 Marks)
b. Differentiate between Mahayana and Hinayana Viharas spatially and functionally. (08 Marks)

Module-2

- 3 Ladkhan is a glorified version of village council hall. Highlight the similarities and its acceptance as a temple form. Explain the temple characteristics with plan and elevation. (20 Marks)

OR

- 4 Write short notes on:
a. Bheema Ratha
b. Deograh temple
c. Pallawan Pillars
d. Arjuna Ratha. (20 Marks)

Module-3

- 5 Explain in detail the layout and planning of Brihadeshwara temple, Tanjore. (20 Marks)

OR

- 6 Explain the planning of Madurai temple in detail. (20 Marks)

Module-4

- 7 a. Explain the general characteristics of Hoysala architecture with sketches. (08 Marks)
b. Explain the temple structures of Channakeshava temple, Belur. (12 Marks)

OR

- 8 a. Explain the evolution of North Indian Shikhara with sketches. (10 Marks)
b. Elaborate and explain the important features of Lingaraja temple in Orissa. (10 Marks)

Module-5

- 9 a. Explain the architectural design features of Sabha Mandapa, temple of Surya at Modhera with help of a neat sketch of ground plan. (10 Marks)
b. With suitable sketches, explain the design development over Khajuraho temples – Kandariya Mahadev temples. (10 Marks)

OR

- 10 With help of a neat sketch of plan and elevation, explain Vijaya Vittal temple at Hampi. (20 Marks)

* * * * *

Important Note : 1. On completing your answers, compulsorily draw diagonal cross lines on the remaining blank pages.
2. Any revealing of identification, appeal to evaluator and /or equations written eg, 42+8 = 50, will be treated as malpractice.

CBCS SCHEME

USN

--	--	--	--	--	--	--	--	--	--

21ARC44

Fourth Semester B.Arch. Degree Examination, June/July 2023

Building Services – II

Time: 3 hrs.

Max. Marks: 100

Note: Answer any FIVE full questions, choosing ONE full question from each module.

Module-1

- 1 a. What are the various ways for 'Green Power Generation'? Explain briefly, the integration of any such technology in a building project with the help of example of any built project. (10Marks)
- b. Write short notes on –
- 'Substations' Transmission and Distribution system.
 - Under Ground cabling versus overhead cabling for Transmission and Distribution System. (10 Marks)

OR

- 2 a. Discuss in detail any two sources of electricity generation. (10Marks)
- b. Provide a Schematic diagram to explain electricity transmission and distribution system from source to consumer, mention role of various components involved in the process briefly. (10 Marks)

Module-2

- 3 a. Write short notes on –
- Transformers
 - H T Metering and Sub metering panels. (10 Marks)
- b. Explain Different types of cable installation systems used in building projects, with sketches. (10 Marks)

OR

- 4 a. Explain the step by step strategy to design a "NET ZERO ENERGY GREEN BUILDING". (10 Marks)
- b. Write short notes on –
- Diesel Generators
 - UPS System. (10 Marks)

Module-3

- 5 a. What is the basic principle behind "Lightning protection systems" for building? When does providing such a system becomes imperative for a building project? (10 Marks)
- b. Explain in detail, any TWO protective devices used in Building Electrical Systems. Use sketches to elaborate. (10 Marks)

OR

- 6 Write short notes on –
- Protection Relays
 - Earth Leakage Circuit Breaker
 - Pipe Earthing System
 - Faraday's Cage – Lightning Protection Systems. (20 Marks)

Module-4

- 7 Write short notes on –
- Recommended Lux levels.
 - Integration of Day lighting with Artificial Lighting.
 - Ambient, Task and Accent lighting.
 - Indirect & Direct Lighting Luminaries.

(20 Marks)

OR

- 8 For a “Design Studio” of Size - 10m × 20m × 4m with sub areas – (Reception + waiting), 10 people meeting room work station for 10 people, (Printing area + Library). Design the lighting layout and justify the choice of Luminaries + Lamps, Positioning and spacing, and controls proposed –
- Qualitatively.
 - Quantitatively.
- Give the justification using sketches / sections / part plan calculations etc.

(20 Marks)

Module-5

- 9 Write short notes on –
- LAN Systems
 - BMS
 - Connected load
 - Demand load

(20Marks)

OR

- 10 For an Airbnb with one Bed room + one Toilet + kitchenet + utility in Bangalore.
- Make Electrical Layout showing –
 - Lights + Controls
 - Fans + Controls
 - Specific Equipment socket
 - Extra power sockets
 - Extra Low voltage points
 - Main Distribution Board
 - Metering Board
 - Make a point matrix and calculate the connected load, Demand Load and total units consumption in kWh in the month of NOVEMBER .
Assume appropriate wattage ratings, load and diversity factors, and usage hours.

(14 Marks)

(06 Marks)

GBCS SCHEME

21ARC46/21CIP46

USN

--	--	--	--	--	--	--	--	--	--

Question Paper Version : B

Fourth Semester B.Arch. Degree Examination, June/July 2023 Constitution of India and Professional Ethics

Time: 1 hr.]

[Max. Marks: 50

INSTRUCTIONS TO THE CANDIDATES

1. Answer all the **fifty** questions, each question carries one mark.
2. Use only **Black ball point pen** for writing / darkening the circles.
3. **For each question, after selecting your answer, darken the appropriate circle corresponding to the same question number on the OMR sheet.**
4. Darkening two circles for the same question makes the answer invalid.
5. **Damaging/overwriting, using whiteners** on the **OMR** sheets are strictly prohibited.

-
1. How many times the president of India can seek re-election to his post?
a) once b) 3 times c) 2 times d) Any number of times
 2. When was Supreme Court of India first inaugurated?
a) 15th August, 1947 b) 26th November, 1949
c) 28th January, 1950 d) 30th January, 1949
 3. Which is the highest judicial authority in India whose decisions are binding on all courts?
a) Supreme court b) Parliament
c) Law minister d) Lok Sabha
 4. How many Judges are there in the Supreme Court?
a) 26 judges including the Chief Justice of India
b) 30 judges including the Chief Justice of India
c) 31 judges including the Chief Justice of India
d) 49 judges including the Chief Justice of India
 5. Who appoints the judges of the Supreme Court?
a) Prime Minister b) Chief Justice of India
c) Lok Sabha d) President
 6. Which among the following is NOT a criteria for being eligible to be a judge of the Supreme Court?
a) Judge of one high court or more (continuously), for at least five years.
b) An advocate of Supreme Court for at least ten years
c) A distinguished jurist in the opinion of the president
d) Above 40 years of age

7. What does the writ of habeas corpus mean?
- The arrested person must be brought before the court, that holds the right to set the person free if the grounds of arrest are found to be faulty.
 - It is issued when an office holder is found to misuse his duties.
 - It is issued by higher courts when they find that lower courts have made judgments beyond their powers of jurisdiction
 - It is issued when the court finds that the office holder is illegally holding that position.
8. What does the writ of prohibition mean?
- The arrested person must be brought before the court, that holds the right to set the person free if the grounds of arrest are found to be faulty.
 - It is issued when an office holder is found to misuse his duties.
 - It is issued by higher courts when they find that lower courts have made judgments beyond their powers of jurisdiction.
 - It is issued when the court finds that the office holder is illegally holding that position.
9. Which of the following statements is not true?
- The institution of High Court in India was first formed in 1862.
 - Article 214 to 231 of the Indian Constitution envisages about the powers of the High Court.
 - Only Delhi is a union territory which has its own High Court
 - Only Parliament determines the number of judges in the High Court
10. Who can extend the jurisdiction of a High Court?
- Parliament of India
 - President of India
 - Supreme Court of India
 - The Governor of the state
11. In case a President dies while in office, the Vice President can act as President for a maximum period of
- 1 year
 - 3 months
 - 6 months
 - 2 years
12. The Union Council of Ministers consists of
- Cabinet Ministers, Minister of State and Deputy Ministers
 - Cabinet Ministers and Chief Ministers of the States
 - Prime Minister
 - Cabinet Ministers
13. Who administers the oath of office to the President of India before he enters upon the office?
- Chief Justice
 - Speaker
 - Vice President
 - Prime Minister
14. Which Article of the constitution empowers the president to appoint a Commission to investigate the condition of backward classes in general and suggest ameliorative measures?
- Art 342
 - Art 344
 - Art 340
 - Art 339
15. Who can initiate impeachment proceedings against the President of India?
- Either House of Parliament
 - Any vidhan Sabha
 - Only Lok Sabha
 - Rajya Sabha

16. What is the minimum age for appointment as a Governor?
 a) 35 years
 b) 40 years
 c) 25 years
 d) 30 years
17. Chief Minister of a State is responsible to
 a) Prime Minister
 b) Rajya Sabha
 c) Legislative Assembly
 d) Governor
18. The administrative and operational control of the Armed Forces is exercised by
 a) Cabinet Committee on Political Affairs with Prime Minister as the Chairman
 b) Ministry of Defense
 c) Three Chiefs of the Army, Navy and Air Force Staff
 d) President
19. What is the position of a Minister of State in the Central Government?
 a) He is a Minister of Central Government but not a member of a Cabinet
 b) He looks after the interests of the State Cabinet
 c) He is the nominee of the State Governor
 d) He is the nominee of the State Cabinet
20. Who among the following is directly responsible to Parliament for all matters concerning the Defense Services of India?
 a) President
 b) Prime Minister
 c) Defense Minister
 d) Cabinet Committee on Political Affairs
21. Consider the following four statements. Which among them are True?
 i) Prime Minister of India must only be a member of Lok Sabha.
 ii) Prime Minister of India can be a member of both Lok Sabha and Rajya Sabha.
 iii) British Prime Minister must only be a member of the Lower House.
 iv) British Prime Minister can be a member of the Lower House as well as Upper House.
 a) Only (i) and (iii)
 b) Only (i) and (iv)
 c) Only (ii) and (iii)
 d) Only (ii) and (iv)
22. Who discharges the duties of the President in the event of President and Vice-President being not available?
 a) The Prime Minister
 b) The Chief Justice of India
 c) The Speaker of Lok Sabha
 d) The Attorney General of India
23. The three types of Justice referred in our Preamble are
 a) Social, Economic and Political
 b) Economic, international and political
 c) Economic, religious and social
 d) Religious, social and political
24. The objective of 'unity and integrity of the nation' was included in the preamble by
 a) 26th Amendment
 b) 44th Amendment
 c) 42nd Amendment
 d) 76th Amendment
25. Articles 19 provides
 a) Six freedoms
 b) Seven freedoms
 c) Five freedom
 d) Two freedoms

26. 'Right against exploitation' seeks to protect the weaker section of the society by
- Giving equal pay for equal work for men and women.
 - Prohibiting human trafficking and beggar.
 - Providing compulsory education for children below the age of 14 years.
 - Forcing a person to work against his will without payment.
27. The Chairman of the Constituent Assembly was and was the Chairman of the Drafting Committee.
- Dr. Rajendra Prasad and Dr. B. R. Ambedkar
 - Dr. B. R. Ambedkar and Dr. Rajendra Prasad
 - Pt. Jawaharlal Neharu and Mahatma Gandhi
 - Sardar Vallabhbhai Patel and Dr. Rajendra Prasad
28. Who of the followings, are not appointed by the President on the advice of the Prime Minister?
- The Chief Justice and other Judges of Supreme Court
 - The Chairman and Members of Union Public Service Commission
 - The Governor of the state
 - The Speaker of Lok Sabha
29. What is the minimum age in years for becoming MP at Lok Sabha and Rajya Sabha?
- 25 and 30
 - 30 and 25
 - 18 and 25
 - 25 and 18
30. Who among the following enjoys the rank of a Cabinet Minister of the Indian Union?
- Deputy Chairman, Rajya Sabha
 - Deputy Chairman of the Planning Commission
 - Secretary to the Government of India
 - None of these
31. 'Secular' means
- Full authority of Government to legislate on its people
 - No King or Queen, President is the Head of the State
 - Treating all religions equally
 - People's Government
32. What is the minimum age to become a member of Lok Sabha
- 18 Years
 - 25 Years
 - 21 Years
 - 30 Years
33. How many nominated members are there in Rjya Sabha?
- 10 Members
 - 11 Members
 - 12 Members
 - 15 Members
34. Which article of the constitution deals with Money Bill?
- Article 110 of the Indian Constitution
 - Article 108 of the Indian Constitution
 - Article 100 of the Indian Constitution
 - Article 80 of the Indian Constitution
35. What is duration of term of the members of the Rajya Sabha?
- 5 Years
 - 4 Years
 - 6 Years
 - 7 Years

36. Which of the following are not sessions of the Lok Sabha?
 a) Budget Session
 b) Monsoon Session
 c) Summer Session
 d) Winter Session
37. The budget is also known as
 a) Annual financial Statement
 b) Monthly Financial Statement
 c) Receipt and Expenditure Statement
 d) Taxation Statement
38. The Parliament of India consists of the following
 a) President
 b) Lok Sabha and Rajya Sabha
 c) Both a and b
 d) None of these
39. Who appoints the Prime Minister?
 a) Council of Ministers
 b) President
 c) Majority party
 d) Lok Sabha
40. Consider the following statements. Which among them are True?
 i) Article 75 provides information on the appointment and selection of Prime Minister
 ii) A person must always prove his majority in Lok Sabha before his appointment as Prime Minister by the President
 iii) A person may be appointed as Prime Minister by the President who must prove his majority later
 iv) A person who is not a member of Lok Sabha or Rajya Sabha can be appointed as Prime Minister.
 a) Only (i) and (ii)
 b) Only (i), (iii) and (iv)
 c) Only (i), (ii) and (iv)
 d) Only (i)
41. A person who is not a member of Parliament can be appointed as a Minister by the President for a maximum period of
 a) 9 months
 b) 3 months
 c) 12 months
 d) 6 months
42. Which one of the following can be the President of India declare?
 a) Emergency due to threat of war, external aggression or armed rebellion
 b) Emergency due to breakdown of constitutional machinery in the state
 c) Financial emergency on account of threat to the financial credit of India
 d) All of these
43. The President can be removed by impeachment procedure on the ground of violating the Constitution by
 a) The Supreme court
 b) The Lok Sabha only
 c) Both the House of Parliament
 d) The High court
44. Directive Principles of State Policies were incorporated in the Constitution with a view to
 a) Ensure a democratic government in the country
 b) Provide a strong Central Government
 c) Establish Welfare State
 d) Raise the living standard of the weaker sections of the society

45. When can a President use his discretion in appointing the Prime Minister?
a) When no political party enjoys a clear majority in the Lok Sabha
b) Only when the Lok Sabha has been dissolved.
c) In all circumstances
d) In no circumstances
46. If in a country there happens to be the office of monarchy as well as a Parliamentary form of government this monarch will be called
a) Head of the State
b) Head of the Cabinet
c) Head of the Government
d) Both Head of Government and State
47. One feature distinguishing the Rajya Sabha from the Vidhan Parishad is
a) Power of impeachment
b) Indirect election
c) Nomination of members
d) Tenure of membership
48. Who, among the following, has the final right to sanction the expenditure of public money in India?
a) Speaker
b) President
c) Prime Minister
d) Parliament
49. Which of the following is not an essential qualification for appointment as a Governor?
a) He must be a member of either House of Parliament.
b) He should be a domicile of the state to which he is being appointed.
c) He should be a citizen of India.
d) He must have completed the age of 35 years.
50. The President nominates 12 members of the Rajya Sabha according to
a) Their performance as office bearers of culture societies.
b) The recommendations made by the Vice President.
c) Their role played in political set up of the country.
d) Their distinction in the field of science, art, literature and social service.

USN

--	--	--	--	--	--	--	--	--	--

Question Paper Version : D

Fourth Semester B.Arch./B.Planning Degree Examination, June/July 2023
Universal Human Values and Professional Ethics

Time: 1 hr.]

[Max. Marks: 50

INSTRUCTIONS TO THE CANDIDATES

1. Answer all the **fifty** questions, each question carries one mark.
2. Use only **Black ball point pen** for writing / darkening the circles.
3. **For each question, after selecting your answer, darken the appropriate circle corresponding to the same question number on the OMR sheet.**
4. Darkening two circles for the same question makes the answer invalid.
5. **Damaging/overwriting, using whiteners** on the **OMR** sheets are strictly prohibited.

-
1. Many human values seem good or right due to
 - a) Positive feeling
 - b) internal happiness
 - c) Natural acceptance
 - d) All the above
 2. Which of the following is a positive value?
 - a) Self respect
 - b) Anger
 - c) Fear
 - d) Narrow mindedness
 3. What are the basic human aspirations?
 - a) Continuous happiness
 - b) Continuous Prosperity
 - c) Both (a) and (b)
 - d) None of the these
 4. What is the content of self-exploration?
 - a) What is my desire?
 - b) What is the program to achieve the desire?
 - c) Both (a) and (b)
 - d) None of the above

5. Self-exploration demands examination and _____ of our beliefs again and again
 - a) Validation
 - b) Presentation
 - c) Demonstration
 - d) Representation
6. Two basic things in the content of self-exploration are to know my basic desires in life and second is to know how to _____
 - a) Perform these
 - b) Remove these
 - c) Fulfill these
 - d) Forgot these
7. Natural acceptance and _____ are two main process of knowing
 - a) Self-actualisation
 - b) Self-control
 - c) Self-exploration
 - d) Self evaluation
8. If something is _____ to us, without any force or compulsion, then it is often correct and does not change with time and people.
 - a) Not acceptable
 - b) Completely acceptable
 - c) Naturally acceptable
 - d) Less acceptable
9. The characteristics of natural acceptance are
 - a) Natural acceptance does not change with time and place
 - b) It does not depend on the place and our beliefs
 - c) it is constant and same for all of us
 - d) All the above
10. Most important condition needed to make us happy is _____
 - a) Right understanding
 - b) Right utilization
 - c) Right guidance
 - d) Right direction
11. What is the state of linking and a holistic and all – encompassing state of the mind that creates inner harmony?
 - a) Prosperity
 - b) Happiness
 - c) Innateness
 - d) Self - organize
12. What helps human beings to transform from animal consciousness to human consciousness
 - a) Right attitude
 - b) Prosperity
 - c) Wealth
 - d) Right understanding

25. Acquiring more physical facility than required leads to get only _____
- Self satisfaction
 - Right understanding
 - Happiness
 - Prosperity
26. Value education inculcates _____ in us
- Preconditioning
 - Fear
 - Right Understanding
 - Assumptions
27. Value education gives us
- Proposal
 - Self motivation, self discipline,
 - Self verification
 - All of these
28. Moral education makes us
- Learn do's and don'ts
 - To Understand proposals with self verification
 - Self motivated
 - Self discipline
29. Value education is
- Universal
 - Rational
 - Verifiable
 - All of these
30. The subject which enables us to learn the skills is called
- Skill development
 - Value education
 - Moral education
 - Phycology
31. Value education deals with _____
- What is universally valuable to all of us
 - What is conductive to our individual and collective happiness
 - Enables to be in harmony with ourselves, other and rest of nature
 - All the above
32. The need of value education is for
- Correct identification of our aspiration
 - Understanding universal human value to fulfill our aspirations in continuity
 - Evaluation of beliefs
 - All the above

33. What are the guidelines of value education?
a) Universal in nature
b) Rational or logical
c) Natural and verifiable
d) All the these
34. Value education enable us :
a) To understand our needs
b) Visualise our goals correctly
c) Indicate the direction for their fulfillment
d) All of these
35. Technology is only means to achieve what is considered
a) Valuable for science
b) Valuable for technology
c) Valuable for humans
d) None of these
36. There is need to supplement
a) Technical education with science
b) Technical education with history
c) Technical education with politics
d) Technical education with value education
37. The purpose of value education is to
a) Make the syllabus easy
b) Foster universal core value
c) Develop values in individuals
d) Both (a) and (c)
38. Self exploration uses two mechanisms – natural acceptance and
a) Reason
b) Experimental validation
c) Logical thinking
d) Theoretical concepts
39. Harmony should be maintained in
a) Between body and life
b) Between self and body
c) Between self and society
d) All of the above
40. A harmonious world is created by values at 4 levels, they are
a) Home, family, society and world
b) Individual, family, society and nature/existence
c) Individual, family, city and universe
d) None of the above

41. The value education is the education by which we can
 a) Learn new technology
 b) Do new research
 c) Transform from animal consciousness to human consciousness
 d) None of above
42. Process of self exploration leads to
 a) Realisation and understanding
 b) Prosperity
 c) Wealthy
 d) Peace
43. Happiness may be defined as
 a) Being in harmony
 b) If there is synergy in it then I like to be in that state
 c) If there is harmony in it then I like to be in that state
 d) All of the above
44. The subject which enables us to understand human aspiration, or what is really valuable for human being is called
 a) Education
 b) Value Education
 c) Spiritual Education
 d) Skill development
45. The subject which enables us to learn the science, technology, management and other skills for fulfilling out aspiration is called _____
 a) Education
 b) Value Education
 c) Spiritual Education
 d) Skill development
46. Most of the time and effort is being invested in _____
 a) Relationship
 b) Right Understanding
 c) Physical facility
 d) Family
47. One of the basic desire of every human being is to be always _____
 a) Sad
 b) Happy
 c) Laugh
 d) Earn money
48. What is the most basic human aspirations?
 a) Happiness
 b) Prosperity
 c) Health
 d) Money
49. What are the basic human aspirations?
 a) Happiness and Prosperity
 b) Happiness and Respect
 c) Prosperity and Health
 d) Prosperity and Pease
50. The value of any unit in this existence is in its _____ in the larger order of which it is part
 a) Participation
 b) Existence
 c) Performance
 d) Appearance

CBCS SCHEME

USN

--	--	--	--	--	--	--	--	--	--

18ARC53

Fifth Semester B.Arch. Degree Examination, June/July 2023 Building Services – II

Time: 3 hrs.

Max. Marks: 100

- Note: 1. Answer any FIVE full questions, choosing ONE full question from each module.
2. Support the answers with sketches.**

Module-1

- 1 Define the electricity distribution from the generation station to the end user with a flow chart. Mention the voltage levels at each transmission and distribution station. (20 Marks)

OR

- 2 Write short notes on :
a) Short circuit
b) Closed circuit
c) Renewable energy
d) Parts of cable (20 Marks)

Module-2

- 3 a. Identify the parts of the generator and its working. (10 Marks)
b. Differentiate between rising main, circuit mains and sub mains. (10 Marks)

OR

- 4 Write short notes on :
a) UPS
b) Conduit wiring
c) Solar power stations
d) Energy conservation techniques in electrical systems (20 Marks)

Module-3

- 5 a. Describe the need for protective device in building and elaborate on Faraday's cage. (10 Marks)
b. Recognize the functioning and parts of a circuit breaker and its need in the building. (10 Marks)

OR

- 6 a. Appraise the need for earthing protective devices in buildings and elaborate on pipe earthing. (10 Marks)
b. Interpret the functioning of Franklin rods with a neat sketch. (10 Marks)

Module-4

- 7 Critically analyze the application of Ambient, Accent & Task lights in building with examples. (20 Marks)

Important Note : 1. On completing your answers, compulsorily draw diagonal cross lines on the remaining blank pages.
2. Any revealing of identification, appeal to evaluator and /or equations written eg, 42+8 = 50, will be treated as malpractice.

OR

- 8 a. The point source has an intensity of 2000 candela in all directions and is mounted 4m above the ground. Calculate the Illuminance on the surface directly underneath and at a distance of 3m to the side.
 b. (20 Marks)

Module-5

- 9 Draw an electrical layout for a room and attached bathroom and calculate the connected load considering the following :

Room			Toilet		
Sl No.	Equipment	Nos.	Sl. No	Equipment	Nos.
1	Lights	2	1	Lights	2
2	Fan	1	2	Exhaust fan	1
3	Plug 5amp	1	3	Plug 5 amp	1
4	Telephone	1	4	Geyser	1

(20 Marks)

OR

- 10 Define the types of low voltage electrical systems in buildings.

(20 Marks)

CBCS SCHEME

USN

--	--	--	--	--	--	--	--	--	--

18ARC54

Fifth Semester B. Arch. Degree Examination, June/July 2023 History of Architecture – V

Time: 3 hrs.

Max. Marks: 100

Note: Answer any FIVE full questions, choosing ONE full question from each module.

Module-1

- 1 a. Elaborate of the emergence of Islamic Architecture in 11th century A.D India. Give General characteristic of Islamic style. (10 Marks)
- b. With the help of neat sketches, explain setting and details of Ghiyas-Ud-din Tughlaq tomb and salient features of Tughlaq style. (10 Marks)

OR

- 2 a. Sketch the layout plan of Quwwat – ul – islam old Delhi and explain arrangement of various structure and enlargements. (10 Marks)
- b. With the help of neat sketches, explain high light the antiques of Khirki Masjid in terms of planning and aesthetics. (10 Marks)

Module-2

- 3 a. Explain the architectural character of façade on Westen Iiwan, Atala Masjid, Jaunpur. (10 Marks)
- b. Explain the purpose and architectural features of Adalaj ni Vavs of Gujarat. (10 Marks)

OR

- 4 a. Discuss in detail the layout and design of Ibrahim Rauza, Bijapur with neat sketches. (10 Marks)
- b. Explain with neat sketches :
- i) Eklakhi Tomb
 - ii) Bora Sona masjid
 - iii) Gol Gumbaz
 - iv) Adina Masjid
 - v) Teen Darwaza
- (10 Marks)

Module-3

- 5 a. Illustrate and explain the architectural and structural design features of Jami Masjid, Gulbarga. (10 Marks)
- b. Explain Madrassa of Mohd, Gawan, Bidar, with help of Ground plan and Architecture features. (10 Marks)

OR

- 6 a. Explain the concept of “Char – bagh” with the example as “Humayun’s Tomb” at old Delhi. (10 Marks)
- b. Draw neat and labeled sketches of :
- i) Birbal’s House
 - ii) Panch Mahal
 - iii) Salim Chisti Tomb
 - iv) Buland Darwaza
- (10 Marks)

Important Note : 1. On completing your answers, compulsorily draw diagonal cross lines on the remaining blank pages.
2. Any revealing of identification, appeal to evaluator and /or equations written eg, 42+8 = 50, will be treated as malpractice.

Module-4

- 7 a. Explain Taj Mahal complex at Agra in detail with neat sketch. (08 Marks)
b. Describe in detail the features and significance of Akbar's Mausoleum, highlighting the composition construction method, materials and symbolism. (12 Marks)

OR

- 8 a. Explain the early phase of Colonial Architecture in India with typologies and Architectural character. (10 Marks)
b. Illustrate and explain the architectural design features of Itimad - ud - daulab Tomb. (10 Marks)

Module-5

- 9 a. Explain St. Paul's Cathedral at Calcutta as an example of later colonial style in India, with neat sketches. (10 Marks)
b. Explain with neat sketches Rashtrapati Bhawan at New Delhi. (10 Marks)

OR

- 10 a. Explain Basilica at Born Jesus, Goa with neat sketches. (10 Marks)
b. With neat sketches, explain the architectural Design features of a typical French House, of Pondicherry. (10 Marks)

USN

--	--	--	--	--	--	--	--	--	--

18ARC62

Sixth Semester B.Arch. Degree Examination, June/July 2023
Materials and Methods in Building Construction – VI

Time: 4 hrs.

Max. Marks: 100

Note: Answer any FIVE full questions, choosing one full question from each module.

Module-1

- 1 a. Explain how glass plays an important role in the construction industry. (10 Marks)
 b. Explain any 5 types of glass commonly used in building construction. (10 Marks)

OR

- 2 A shopfront in a mall has to be designed with a frameless glass door for an opening of 3000 × 3600mm. Assuming suitable scales, draw plan, elevation, cross sections and 2 minimum associated details for the same. (20 Marks)

Module-2

- 3 With neat sketches, explain the various support systems the point fixed support glazing uses. (20 Marks)

OR

- 4 a. With neat illustrations, explain any 4 types of structural glazing systems. (10 Marks)
 b. Why is aluminum preferred as a building material? Illustrate with details the common types of sun lowers seen in buildings. (10 Marks)

Module-3

- 5 An artist's studio requires an opening of 3000 × 2700mm to be designed with a wooden sliding folding door design. With suitable scale, draw plan, elevation, cross-sections and any 2 details. (20 Marks)

OR

- 6 An architect's office requires an opening of 3000 × 2700mm to be designed with a UPVC door design. Assuming suitable scales, draw plan, elevation, cross-sections and any 2 details for the same. (20 Marks)

Module-4

- 7 Design and detail an opening of 3600mm × 2700mm for a conference room in an office using aluminium sliding folding doors. Draw the construction mechanism for the same with a layout plan, elevation, cross sections and details related to the same. (20 Marks)

OR

- 8 Explain the working mechanism with neat sketches of a steel sliding folding door. (20 Marks)

Module-5

- 9 A music studio with a recording room of size 4000 × 4500mm requires to be sound proofed using appropriate sandwich panels, provide construction details with suitable sketches for the same. (20 Marks)

OR

- 10 Design and detail a skylight in a terrace for an opening of size 1200 × 1500mm. Draw with suitable scale the plan, elevation, cross-sections and details for the same. (20 Marks)

Important Note : 1. On completing your answers, compulsorily draw diagonal cross lines on the remaining blank pages.
 2. Any revealing of identification, appeal to evaluator and /or equations written eg, 42+8 = 50, will be treated as malpractice.

CBCS SCHEME

USN

--	--	--	--	--	--	--	--	--	--

18ARC63

Sixth Semester B.Arch. Degree Examination, June/July 2023

Building Services – III

Time: 3 hrs.

Max. Marks:100

Note: Answer any FIVE full questions, choosing ONE full question from each module.

Module-1

- 1 Under what circumstances would mechanical ventilation system be proposed in a building by an architect? Describe an apt mechanical ventilation system for a factory and a residence respectively. (20 Marks)

OR

- 2 Explain refrigeration cycle with help of schematic diagram. (20 Marks)

Module-2

- 3 What are the classification of air conditioning systems? Explain any 2 in detail. (20 Marks)

OR

- 4 Define :
i) Clean rooms
ii) Different types of duct systems. (20 Marks)

Module-3

- 5 Answer the following :
i) Explain the different types of elevators based on hoist mechanism.
ii) Explain average waiting time and peak handling capacity. (20 Marks)

OR

- 6 With the help of sketches explain in detail the different components of an elevator. (20 Marks)

Module-4

- 7 Write brief notes on :
i) Common causes of fire and classification of hazards.
ii) Classification of buildings as per NBC. (20 Marks)

OR

- 8 Explain the concept of passive fire protection in buildings. (20 Marks)

Module-5

- 9 Explain in detail with sketches different types of fire sprinkler systems. (20 Marks)

OR

- 10 Explain in detail different types of fire Alarm system. Explain the components and importance of fire alarm system. (20 Marks)

Important Note : 1. On completing your answers, compulsorily draw diagonal cross lines on the remaining blank pages.
2. Any revealing of identification, appeal to evaluator and /or equations written eg. 42+8 = 50, will be treated as malpractice.

CBCS SCHEME

USN

--	--	--	--	--	--	--	--	--	--

18ARC64

Sixth Semester B.Arch. Degree Examination, June/July 2023 Contemporary Architecture

Time: 3 hrs.

Max. Marks: 100

Note: Answer any FIVE full questions, choosing ONE full question from each module.

Module-1

- 1 Explain with sketches, the influence of European Architecture on the planning and architecture of the princely state, Mysore. (20 Marks)

OR

- 2 Explain Indian Institute of Management, Ahmadabad with respect to
- a. Served spaces and servant spaces (10 Marks)
- b. Built environment responding to the philosophy of education of the institute. Support your answer with neat sketches wherever necessary. (10 Marks)

Module-2

- 3 Discuss the contribution of Laurie Baker in shaping the contemporary architecture scenario in India with an example. Support your answer with appropriate sketches. (20 Marks)

OR

- 4 Discuss the ideologies and design philosophies of Ar. Achut Kanvinde using Nehru Science center, Mumbai as example. Support your answer with appropriate sketches. (20 Marks)

Module-3

- 5 Discuss the influence of Le Corbusier in Richard Meier's work. (20 Marks)

OR

- 6 Explain how the principles of Hi-tech architecture expressed in the works of Ar. Norman Foster with an example. (20 Marks)

Module-4

- 7 Elaborate how principle of structural expressionism translated in the design of Pompidou Centre, Paris. (20 Marks)

OR

- 8 What is Zoomorphism in Architecture? Discuss one project of Santiago Calatrava that showcases the fusion of concept, form and function. (20 Marks)

Module-5

- 9 Write short notes on the following architects illustrating one their works.
i) Rem Koolhaas ii) Frank Gehry (20 Marks)

OR

- 10 Explain Deconstructivism. Explain how the principle of deconstructivism is expressed in the works of Ar. Zaha Hadid through one of her buildings. (20 Marks)

* * * * *

Important Note : 1. On completing your answers, compulsorily draw diagonal cross lines on the remaining blank pages.
2. Any revealing of identification, appeal to evaluator and /or equations written eg, 42+8 = 50, will be treated as malpractice.

CBCS SCHEME

USN

--	--	--	--	--	--	--	--	--	--

18ARC66

Sixth Semester B.Arch. Degree Examination, June/July 2023 Landscape Architecture

Time: 3 hrs.

Max. Marks: 100

Note: Answer any FIVE full questions, choosing ONE full question from each module.

Module-1

1 With neat sketches, explain the following:

- i) Sustainability
- ii) Biodiversity
- iii) Taxonomy
- iv) Ecology.

(20 Marks)

OR

2 Describe in detail how landscape as profession, grew from small gardens to large regions landscape. (20 Marks)

Module-2

3 Why is site inventory and analysis important to architectural and landscape architectural projects. Describe the process in detail with neat sketches. (20 Marks)

OR

4 Explain how micro climate of an area influence that landscape. (20 Marks)

Module-3

5 List and explain the various types of street furnitures, with neat and elaborate sketches. (20 Marks)

OR

6 Explain the importance of water and landform as key elements in landscape, examples with neat and detailed sketches. (20 Marks)

Module-4

7 Discuss the works of mayalin and Martha Schwartz contemporary landscape architects, with their concepts and sketches with case study. (20 Marks)

OR

8 Draw neat sketches and explain the characteristic of the garden in the following:

- a. Formal garden
- b. Japanese informal gardens.

(20 Marks)

Module-5

9 Propose a landscape design scheme for a courtyard measuring 6m × 10m for a café in Bangalore. The courtyard is surrounded by a entrance lobby on the shorter side and seating area on the other three sides. Explain your ideas through plan, section, elevation in detail. (20 Marks)

OR

10 What are the design considerations while designing public parks in urban areas? (20 Marks)

* * * * *

Important Note : 1. On completing your answers, compulsorily draw diagonal cross lines on the remaining blank pages.
2. Any revealing of identification, appeal to evaluator and /or equations written eg, 42+8 = 50, will be treated as malpractice.

USN

--	--	--	--	--	--	--	--	--	--

18ARC73

Seventh Semester B. Arch. Degree Examination, June/July 2023
Building Services – IV

Time: 3 hrs.

Max. Marks: 100

Note: Answer any FIVE full questions, choosing ONE full question from each module.

Module-1

- 1 a. Explain Auditory Range and Sensitivity Range of Human Hearing. (08 Marks)
 b. Analyse the behavior of sound in following spaces, Suggest corrective measures if there are defects.
 i) Long rectangular Hall
 ii) Lecture Hall with a concave wall
 iii) Classroom with a dome ceiling (12 Marks)

OR

- 2 a. How does Sabine's law assist in assessing the acoustic environment of an enclosed space? (12 Marks)
 b. Analyse the human perception of loudness of sound with respect to intensity of sound. (08 Marks)

Module-2

- 3 a. A community Hall would be used for lecture sessions and music performance. Suggest suitable acoustic strategy. Give reason and explain. (10 Marks)
 b. Explain the functioning of sound level meter. Elaborate the significance of weighing network in a sound level meter. (10 Marks)

OR

- 4 a. What is NRC? How does NRC assist in identifying the appropriate acoustic material? (08 Marks)
 b. Recommend suitable acoustic materials for the following conditions. Justify and explain.
 i) Absorption at low frequencies sound
 ii) Equal/Even distribution of sound
 iii) Absorption of sound in a specific frequency range
 iv) Absorptive material for a curvilinear wall (12 Marks)

Module-3

- 5 a. What are the considerations to achieve favorable sightlines in an auditorium? (10 Marks)
 b. Enumerate considerations and suggest acoustic strategies for
 i) Indoor swimming pool
 ii) Home theatre (10 Marks)

OR

- 6 a. What are the considerations for halls of speech? (06 Marks)
 b. Enumerate the important design parameters to achieve favorable acoustic environment for an open air theatre. (06 Marks)
 c. Explain the concept of speech privacy and its significance in an open office plan. (08 Marks)

Important Note : 1. On completing your answers, compulsorily draw diagonal cross lines on the remaining blank pages.
 2. Any revealing of identification, appeal to evaluator and /or equations written eg, 42+8 = 50, will be treated as malpractice.

Module-4

- 7 a. Analyse transmission of noise through a three storied framed structure. (10 Marks)
b. What is STC? Suggest one construction detail for floors and walls to avoid transmission of sound through them. (10 Marks)

OR

- 8 a. A school is located on a highway. What are the various sources of noise in the school? Analyse the nature of these noises. (08 Marks)
b. What is Mass Law? Recommend suitable details (atleast 3) to reduce noise from the ventilation system. (12 Marks)

Module-5

- 9 a. Suggest methods to reduce noise in an industrial building due to following : (10 Marks)
i) friction ii) Air turbulence
b. What are the strategies which may reduce noise at town planning level and site planning level? (10 Marks)

OR

- 10 a. A railway line and a highway pass through a residential community. Suggest suitable strategies to avoid noise from the railway line and the highway. (12 Marks)
b. Elaborate the role played by architects/urban planner in shaping the urban soundscape. (08 Marks)

CBCS SCHEME

18ENG74

USN

--	--	--	--	--	--	--	--	--	--

Seventh Semester B.Arch. Degree Examination, June/July 2023 Specification, Quantity and Costing of Buildings

Time: 3 hrs.

Max. Marks: 100

Note: Answer any FIVE full questions, choosing one full question from each module.

Module-1

- 1 a. Define Estimate. "Estimate is never the actual cost but it is approximate cost" Explain briefly. (10 Marks)
b. List and explain the factors affecting estimation of building. (10 Marks)

OR

- 2 Explain the following types of estimate:
i) Preliminary estimate
ii) Detailed estimate
iii) Revised estimate
iv) Supplementary estimate
v) Item rate estimate. (20 Marks)

Module-2

- 3 a. What is a contract? List and explain the different types of contract. (10 Marks)
b. What is a tender document? List the essentials of a tender. (10 Marks)

OR

- 4 Write short notes on:
i) EMD and Security retention.
ii) Measurement book and its importance.
iii) Safety norms to be followed at site.
iv) Administrative and technical sanction. (20 Marks)

Module-3

- 5 a. Define rate analysis. List and explain the sub-head costs taken into account. (10 Marks)
b. List and explain the different factors affecting the rate analysis. (10 Marks)

OR

- 6 Carry out the rate analysis for the following:
i) Earthwork excavation for foundation in ordinary soil.
ii) PCC bedding 1:4:8 for foundation.
iii) Coursed rubble masonry in CM 1:6.
iv) Painting plastered surface including preparation of surface. (20 Marks)

Important Note : 1. On completing your answers, compulsorily draw diagonal cross lines on the remaining blank pages.
2. Any revealing of identification, appeal to evaluator and /or equations written eg, 42+8 = 50, will be treated as malpractice.

Module-4

- 7 Estimate the quantities for the following items of work for a two room building shown in Fig.Q.7.
- Earthwork excavation in foundation.
 - PCC bed concrete 1:4:8.
 - First class brick masonry in CM 1:6.
- [Both long wall and short wall method and centre line method].

(20 Marks)

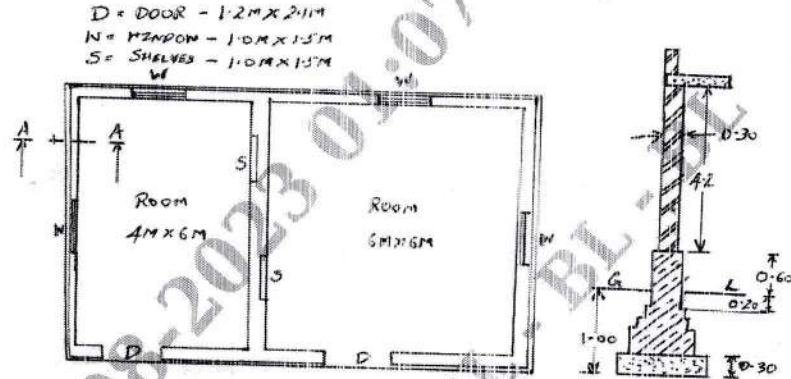
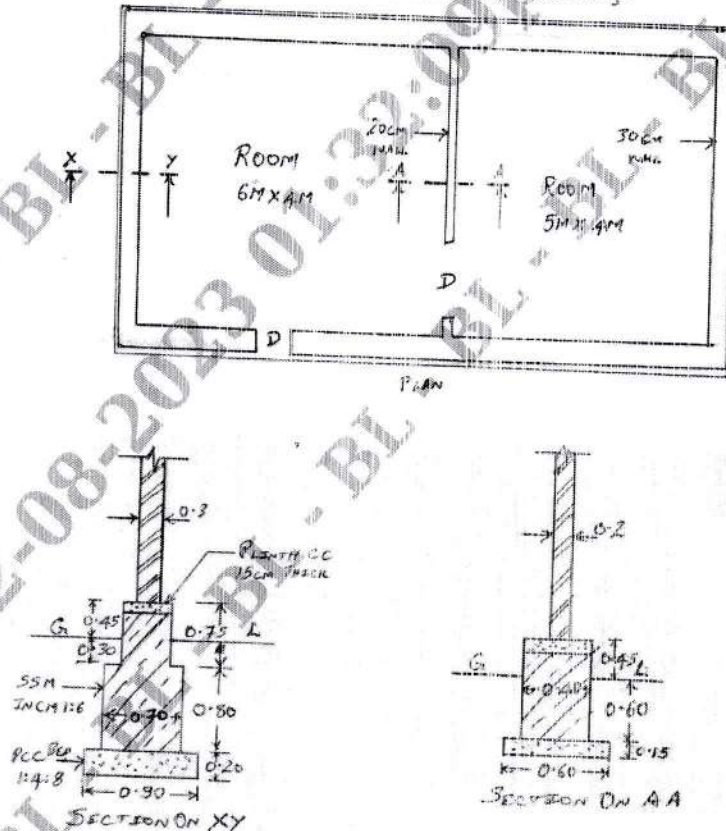

Fig.Q.7

OR

- 8 Estimate the quantities for the following items of work for a two room building shown in Fig.Q.8.
- Earthwork excavation in foundation
 - PCC bed concrete 1:4:8.
 - SSM in CM 1:6 for foundation.
- [Both long wall and short wall method and centre line method].

(20 Marks)



All dimensions are in mm

Fig.Q.8

Module-5

- 9 Estimate the quantity of earthwork for a portion of road for 300m length from the following data. Formation width is 10m, side slopes in banking is 2:1 and side slopes in cutting is 1.5:1.

Distance	0	30	60	90	120	150	180	210	240	270	300
RL of ground	101	100.9	100.5	100.7	100.8	100.6	100	99.8	99.2	99.1	98.5

The formation level at the first chainage is 102. The road is in downward gradient of 1 in 50 upto distance of 120m. Afterward gradient changes to 1 in 100. (20 Marks)

OR

- 10 Explain the following:
- Certificate of virtual completion
 - Liquidated damages
 - Ra bill and final bill
 - Payment certificate
 - Security deposit.

(20 Marks)

* * * * *

CBCS SCHEME

USN

--	--	--	--	--	--	--	--	--	--

18ARC75

Seventh Semester B.Arch. Degree Examination, June/July 2023 Urban Design

Time: 3 hrs.

Max. Marks: 100

Note: Answer any FIVE full questions, choosing one full question from each module.

Module-1

- 1 a. "A city can be understood better through visual experience" Explain this concept in the design perspective of Gordon Cullen. Give relevant sketches through examples wherever deemed fit. (10 Marks)
- b. Explain the role of squares in urban design through an example of an International city and an Indian city. Elaborate on ideology through relevant sketches. (10 Marks)

OR

- 2 a. Explain the urban design terminologies through relevant examples:
i) Neighbour Hood
ii) Street
iii) Block
iv) Building
v) Architectural Elements. (10 Marks)
- b. "A city has a wide scope for perceptions and interpretations" Explain in the context of any historical / heritage city." (10 Marks)

Module-2

- 3 a. Explain the role of walkability and imageability in an urban street through valid examples. (05 Marks)
- b. Explain the various elements of public image through Kevin Lynch's ideologies describe in "Image of a City". (15 Marks)

OR

- 4 a. Elaborate your views on enhancing the quality of urban design through pedestrian. (08 Marks)
- b. Explain the social and cultural influence on architecture an urban design through the principles established in the book "Death and life of great American cities" by Jane Jacob. (12 Marks)

Module-3

- 5 a. Elaborate on the concepts of transformation of street design through organization of space and form. (10 Marks)
- b. Theories and works by Collin Rowe on street designs and public square façade. (10 Marks)

OR

- 6 Describe your personal experiences while walking through streets in your neighborhood in the context of the following:
i) Built, semi built and unbuilt spaces:
ii) Scale and Proportion
iii) Non motorized transport inter ventions
iv) Historic and heritage value of building. (20 Marks)

Important Note : 1. On completing your answers, compulsorily draw diagonal cross lines on the remaining blank pages.
2. Any revealing of identification, appeal to evaluator and /or equations written eg, 42+8 = 50, will be treated as malpractice.

Module-4

- 7 Write short notes on any two of the following in terms of public spaces:
- Connaught place, Delhi
 - Gateway of India, Mumbai
 - Taj Mahal, Agra
 - Esplanade, Kolkata
 - Commercial street, Bangalore.

(20 Marks)

OR

- 8 The urban streets are majorly influenced by the formal and informal environments which affect the legibility and imageability of streets. Explain in terms of any one Indian city.

(20 Marks)

Module-5

- 9 Elaborate on the role of Human activities in enhancing the built environment by choosing any two of the following derivatives:

- Any shopping mall or recreational space you have witnessed.
- Any commercial or industrial complex you have come across.
- Any food street or food market you have been to.

(20 Marks)

OR

- 10 Elaborate on the principles laid down by Kenneth Frampton and Charles Correa on critical regionalism. Also derive its role in Indian context. Give relevant sketches.

(20 Marks)

* * * * *

CBCS SCHEME

USN

--	--	--	--	--	--	--	--

18ARC82

Eighth Semester B.Arch. Degree Examination, June/July 2023 Materials and Methods in Building Construction - VIII

Time: 4 hrs.

Max. Marks: 100

Note: Answer any FIVE full questions, choosing ONE full question from each module.

Module-1

- 1 a. Explain prefabrication, its advantages and disadvantages. (10 Marks)
- b. Elaborate on comparative analysis between aluminium form work and conventional timber form work. (10 Marks)

OR

- 2 Write short notes on box Caisson's and Cofferdam. (20 Marks)

Module-2

- 3 a. What is Data Silo and Cloud collaboration? (10 Marks)
- b. What do you understand by the term simulation? Explain its benefits. (10 Marks)

OR

- 4 a. What is 3D printing and explain its advantages. (10 Marks)
- b. What is BIM? Elaborate on the use of BIM in construction management. (10 Marks)

Module-3

- 5 a. Explain Life Cycle Analysis. (05 Marks)
- b. Describe the four stages that are assessed in a life cycle assessment. (15 Marks)

OR

- 6 a. Differentiate between repairs and retrofits. (10 Marks)
- b. Explain two techniques for each on repairs and retrofits. (10 Marks)

Module-4

- 7 What do you understand by GRIHA? Explain any three major components that result in points for GRIHA rating. (20 Marks)

OR

- 8 Explain methods of Harvesting and Conserving energy to achieve a Net Zero Energy Building. (20 Marks)

Module-5

- 9 Explain in detail any four smart materials and its application in the construction industry. (20 Marks)

OR

- 10 Explain in detail any four Nano material and its application in the construction industry. (20 Marks)

Important Note : 1. On completing your answers, compulsorily draw diagonal cross lines on the remaining blank pages.
2. Any revealing of identification, appeal to evaluator and/or equations written eg, 42+8=50, will be treated as malpractice.

CBCS SCHEME

USN

--	--	--	--	--	--	--	--	--	--

18ARC84

Eighth Semester B.Arch. Degree Examination, June/July 2023 Professional Practice

Time: 3 hrs.

Max. Marks: 100

Note: Answer any FIVE full questions, choosing ONE full question from each module.

Module-1

- 1 a. Explain what is meant by profession and business. Why is architecture considered as profession and not business? (10 Marks)
- b. Detail out the compositional structure, advantages and disadvantages of Partnership firm and Limited company. (10 Marks)

OR

- 2 a. What are the duties of an Architect towards Professional Bodies and Authorities? (10 Marks)
- b. What are the different legislative acts useful to architect in his/her profession? (10 Marks)

Module-2

- 3 a. Elaborate on the formation of IIA and its role towards architecture profession. (10 Marks)
- b. List the benefits of conducting architectural competitions. (10 Marks)

OR

- 4 What are the salient features of Architect's Act of 1972? (20 Marks)

Module-3

- 5 a. List the pre-requisites for tendering for client and for the contractor. (08 Marks)
- b. Explain the various processes adopted while selecting a contractor for a project. (12 Marks)

OR

- 6 a. Explain the objectives of contract management. (08 Marks)
- b. Differentiate between
i) Deviation and Escalation ii) Extras and Variation iii) Damages and Contingencies (12 Marks)

Module-4

- 7 a. Elaborate on the powers and duties of an arbitrator. (10 Marks)
- b. Write in brief about the Documents Generally needed for building license. (10 Marks)

OR

- 8 a. Explain the various methods of valuation on the basis of their suitability and basis of valuation. (10 Marks)
- b. What is depreciation? Explain in brief the methods considered to calculate depreciation of a building. (10 Marks)

Module-5

- 9 a. Elaborate the role of architect with Government Finance, Labour and Statutory bodies in building industry. (14 Marks)
- b. Enumerate natural rights and customary rights. (06 Marks)

OR

- 10 a. Discuss various types of easements rights in detail. (10 Marks)
- b. List the factors that are considered and that are not considered while calculating compensation amount under Land Acquisition Act. (10 Marks)

Important Note : 1. On completing your answers, compulsorily draw diagonal cross lines on the remaining blank pages.
2. Any revealing of identification, appeal to evaluator and /or equations written eg, 42+8 = 50, will be treated as malpractice.

CBCS SCHEME

USN

--	--	--	--	--	--	--	--	--	--

18ENG85

Eighth Semester B.Arch. Degree Examination, June/July 2023 Construction and Project Management

Time: 3 hrs.

Max. Marks: 100

Note: Answer any FIVE full questions, choosing ONE full question from each module.

Module-1

1 Write short notes on the following:

- Project scope
- Project budgeting
- Project planning
- Project scheduling.

(20 Marks)

OR

2 Explain in detail the purpose of project management with suitable examples.

(20 Marks)

Module-2

3 Write short notes on the following:

- SWOT analysis.
- Cost/Benefit analysis.

(10 Marks)

(10 Marks)

OR

4 Explain in detail role of the project manager in construction project.

(20 Marks)

Module-3

5

Activity	Duration in days	Preceding	Following
A	3	-	B, C
B	2	A	D, E
C	3	A	F
D	5	B	F
E	6	B, C	F, G
F	5	D, E	-
G	4	E	-

- Draw network diagram and find EST, LST, EFT, LFT.
- Find Total Float (T.F), Free Float (F.F) and Independent Float (I.F).

(10 Marks)

(10 Marks)

OR

6

Activity	T ₁	T ₂	T ₃
AB	2	5	8
AC	2	4	6
BD	3	5	13
BE	2	3	10
CE	4	6	14
CF	4	8	12
EG	6	9	16
FG	4	10	16

- Draw the network diagram and find EST, LST, EFT, LFT.
- Find Total Float, Free Float and Independent Float.

(10 Marks)

(10 Marks) 60

Module-4

7 Explain in detail the quality audits and process analysis in construction projects. (20 Marks)

OR

8 Explain in detail the process of project measurement and control of the construction projects. (20 Marks)

Module-5

9 Explain in detail owning and operating cost of construction equipment. (20 Marks)

OR

10 Write short notes on the following:

a. Hauling Equipments (10 Marks)

b. Hoisting Equipments. (10 Marks)

* * * * *