

# AC OR DC CONVERTER FOR IMPROVING POWER QUALITY IN TRANSMISSION LINES

Fatima.N. Kudchi  
Assistant Professor,  
Dept. of EEE  
BLDEAs College of Engineering and technology,  
Vijayapur,  
VTU Belgaum,  
India  
[fatimankudchi@gmail.com](mailto:fatimankudchi@gmail.com)

June 10, 2018

## Abstract

This paper presents, a transmission lines for improving grid quality by using Ac or Dc power converter. These converters starts with High PF Filters like capacitors and inductors, these both follow Bridge Diode, by this we can get High PF and are used in Passive PF correction (PFC) circuits. In high frequency operation the circuit size reduced, two stage of high frequency PFC converter proposed [1]. With Si-semiconductor devices, switching frequency operates from 10 to several 100 kHz. Ac or Dc PFC converter, wide-band gap devices, switching frequency operates from several 100 kHz to 10 MHzs. Design and control part is solved by regulating output voltage and shaping input current. By changing the Dc link voltage from 400V-800V, line voltage will be within 265V and Power Factor will increase from 0.88 to 0.99

**Key Words:** MATLAB, SIMULINK, SSTLPFC, PFC, Dc/Dc, DLV,

# 1 Introduction

Filters are like capacitors and inductors are used and these both follow Bridge Diode, by doing this we can get High PF and are used in Passive PF correction (PFC) circuits. In a circuit, low line frequency filters are needed but they are heavy. In high frequency operation the circuit size must be reduced. Fig.1 shows SSTLPFC converter. Two Capacitors are used and there ratings are 470 F or 400 V. output side capacitor rating is 100 F. Input inductors and output inductor rating is 27 H or 15 A. Switching frequency is 125 kHz. Transformers turns ratio is 1:2. Switches S1 to S4 are N Channel MOSFETs, the input ac voltage is 90 Vrms and frequency is 60 Hz. Converters starts with High PF.

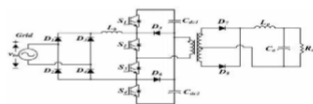

Fig .1 SSTLPFC converters

# 2 OPERATION OF MODES

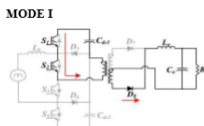

Fig. 2 Mode I

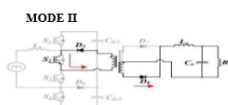

Fig.3 Mode II

This mode is valid for  $t_0$  to  $t_1$ . Switch S1 and Switch S2 are ON and diode D8 conducts in Transformers auxiliary side. In Transformers primary side apply  $V_{dc}/2$ , and capacitor Cdc1 discharges to the load and  $V_{L0} = V_{dc}/2N - V_0$ .

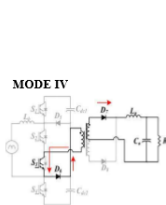

Fig.4. Mode III

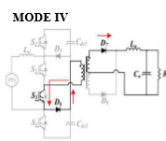

Fig.5. Mode IV

This mode is valid for  $t_1$  to  $t_2$ . Switch S2 remains ON and Switch S1 OFF and diode D5 conducts. Transformers Primary side applies zero voltage and Current freewheels. Output voltage of inductor is equivalent to  $V_0$  and output current of inductor is reduces straightly.

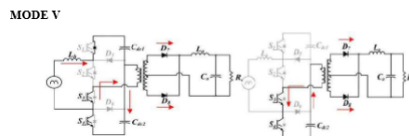

Fig.6. Mode V

This mode valid for  $t_2$  to  $t_3$ , Switch S2 and Switch S3 both are ON, that time Transformers Primary side applies zero voltage and continuous Current freewheels. Under output Current and Output voltage inductor is continuously decreases. That time  $V_{in}$  connected crosswise over  $L_b$ .

This mode is valid for  $t_6$  to  $t_7$ , Switch S4 OFF and Switch S3 is ON. Both diode D6 and D7 are conducts and D6 allows leakage current to freewheel. Under  $V_0$  output current is decreases. Switch S2 is OFF and Switch S4 and S3 are ON, this mode valid for  $t_3$  to  $t_5$ . Energy Stores in inductor and transfers that energy into Dc link capacitor. In between  $V_{in} - V_{dc}$  inductor current decreases straightly, that time Transformers primary side apply  $V_{dc}/2$ . In leakage inductance, current is transferred to  $C_{dc2}$  in this situation output current flows from D8 to D7.

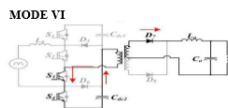

Fig. 7 Mode VII

This mode is valid for  $t_7$  to  $t_8$ . Switch  $S_2$  and Switch  $S_3$  are ON. Input side of energy is stored in inductor and its operation is same as mode 3. Excluding that in mode 3 primary side current is opposite.

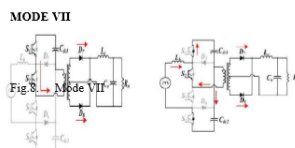

Fig.8. Mode VII

This mode is valid for  $t_5$  to  $t_6$ . Switch  $S_3$  and Switch  $S_4$  are ON and diode  $D_7$  conducts. That time  $C_{dc2}$  is discharges and Transformers primary side apply  $V_{dc}/2$  and  $V_{L0} = V_{dc}/2N - V_0$ . in a discontinuous conduction mode input current always at zero.

This mode valid for  $t_8$  to  $t_{10}$ .  $S_3$  is OFF and  $S_1, S_2$  are ON. Its operation is same as mode 4. In inductor energy is stored and that energy transferred to Dc bus capacitor. In this situation output current of inductor flows in between  $D_7$  and  $D_8$ .

### 3 HIGH POWER FACTOR:

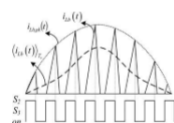

Fig 9 Input Inductor Current

PF will be high when DLV is maximum so i/p current turns out to be Discontinuous. When Peak Current follows a sinusoidal waveform, converter operates that time Duty ratio must be constant.

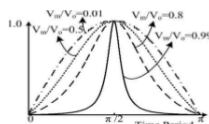

Fig 10 .Input current is designed for different DLV

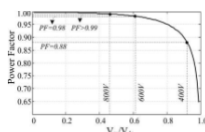

Fig 11 PF v/s Vm/Vdc

In Fig 11 shows Input current is designed for different DLV. To obtain input current as pure sinusoidal waveform, Dc Link Voltage must be infinity. In Fig 12 shows PF v/s Vm/Vdc.

## 4 DESIGN CONSIDERATIONS

**1 Input Inductor:** In Discontinuous Conduction Mode PF is High and at constant Duty ratio PFC converters operate. In DLV, Input Inductor and Duty ratio, Power is transfer this happens in operation of DCM. Using equation (1), the Lb can be written as

$$L_B = D1^2 Vm^2 \int_0^{\frac{\pi \alpha^2(\omega t)}{(1-Vm \sin(\omega t))/Vdc}} \frac{d(\omega t)}{\omega P_o} \tag{1}$$

### 2 Output Inductor:

Output inductor is fully depends on its design principle so it may be Continuous or Discontinuous. At Light Load condition operation of converter can transfer to DCM so that output inductor size will be decreases. Output inductor can be written as

$$L_0 \geq V_0^2 (0.5 - D_2) T_{sw} / 2P_x \tag{2}$$

**Transformer ratio:** At Steady State Duty ratio of S1 and S4, indicated as D2, it can be written as

$$D_2 = \frac{NV_0}{V_{dc}} \tag{3}$$

$$ID5, a = \frac{10}{N} - \left(\frac{V_0}{2NL0}\right) (0.5 - D2)Ts$$

N = number of turns ratio, in DCM D2 can be written as

$$D_2 = \sqrt{2L0 / RTs \left(\left(\frac{Vdc}{NVO} - 1\right)^2 - 1\right)} \tag{4}$$

The practical voltage of Transformer by turning ON S1 to S2 or S3 to S4 is limited to 0.5

Fig 13 show Switches and Diodes operations in less time period Switches and Diodes operations in less time period are shown in Fig 13. Dc is known as Duty ratio and it can be written as

$$D_2 = \sqrt{2L0 / RTs \left(\left(\frac{Vdc}{NVO} - 1\right)^2 - 1\right)} \tag{4}$$

Fig 13 Switches and Diodes operations in less time period

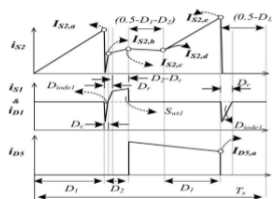

Inductor current can be written as

$$Dc(t) = \frac{7Vdc - V0}{\left(\frac{2N}{N} - V0\right) Lb - NL0(Vdc - Nin(v))} \tag{6}$$

Minimum Current in Transformer can be written as

$$Is2, b (t) = \frac{10}{N} - \left(\frac{Vdc - V0}{2NL0}\right) \left(\frac{D2}{2} - Dc (t)\right) Ts$$

Peak Current in Transformer can be written as

$$Is2, c = \frac{10}{N} + \left(\frac{Vdc - V0}{2NL0}\right) D2Ts \tag{8}$$

ID5 can be calculated as Standard diode currents can be written as

$$iD1,4, ave (t) = \frac{1}{2} Is2, a(t) (Dc(t) + D1(t))$$

Standard current of freewheeling Diodes can be written as

$$ID5,6, ave (t) = \frac{Is2, b(t) + ID5, a}{2} (0.5 - D2) \tag{9}$$

## 5 POWER FACTOR CORRECTION TECHNIQUES

To improve PF and to eradicate Current harmonics several methods are used. PFC has two techniques, to decrease or to eradicate Current harmonics and they are

### 1. Passive power factor correction:

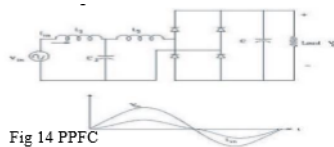

Fig 14 PPFC

Fig 14 PPFC

In PPFC techniques, two inductors and one capacitor are connected to Ac mains line and Diode rectifier converter as shown in Fig.6. It is simple and harsh. In Passive correction technique PF is not high. It has large size and its weight should be heavy. At this moment it is not suitable for Current trends of harmonic norms. Generally in PPFC Power rating are not more than 25W and above this value the PPFC will be heavy. It has high Efficiency and its EMI is Low. For 50/60 Hz, power distribution systems, the LC filter is tuned at the fifth harmonic frequency and a series tuned Filter is connected in corresponding to the rectifier to trap third harmonic current to prevent damping the fundamental component.

### 2.Active power factor correction:

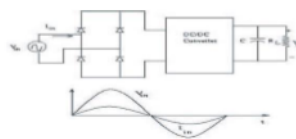
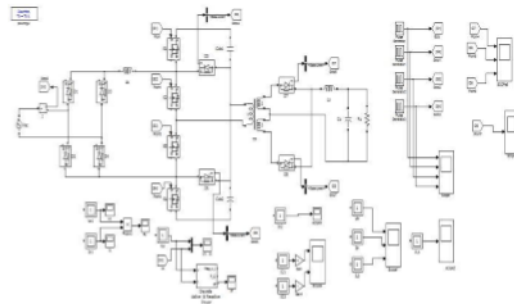

Fig 15 APFC

APFC presents a extra challenging converter design and control problem as compared to the passive approach. Usually two control rings are required to achieve this: first a wide bandwidth internal current ring to shape the Input Current; second, a narrow bandwidth outer ring is designed to control the output dc Voltage of the load.

**4. Two Stage Power Factor Correction:** Two-stage PFC using an input current shaper go behind a Dc/Dc converter is fundamental approach for active PFC. By using Nonlinear carrier control, Hysteresis control, Current mode control we can shape Input Current. Stage of Dc/Dc converters are buck, Fly back or Forward converter. TSPFC has good Hold up time, High PF and its Input harmonics should be Low. So these all qualities show greater performance of TSPFC.

## 6 SIMULINK DIAGRAM



## 7 SIMULATION DIAGRAM

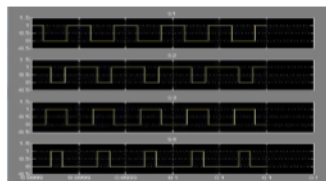

Fig.7.1 switching operations

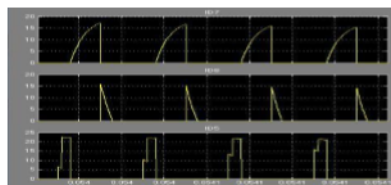



Fig.7.2 output Inductor voltage

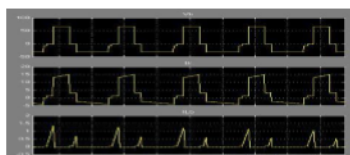

Fig.7.3 Transformers Voltage and Current Wave form

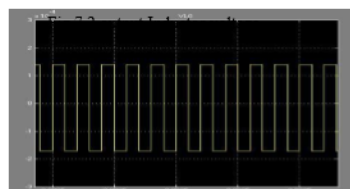
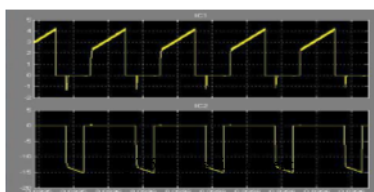
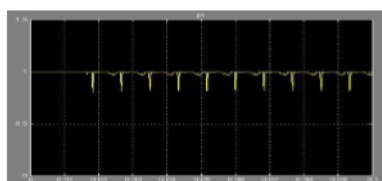

Fig. 7.4 Diodes side current



7.5 capacitors side current D6



7.6 Power Factor of conventional circuit



7.7 current flows in Diode D6

## 8 CONCLUSION

In low power applications we can use this SSTLPFC converter and shows, in a constant duty ratio how high Power Factor will be achieved by using minimum number of Diodes or Switches. By adding inductor and Diode Bridge in SSTL converter the switching operation is modified and consistent. Design and control part is solved by regulating output voltage and shaping input current. By changing the Dc link voltage from 400V-800V, line voltage will be within 265V and Power Factor will increase from 0.88 to 0.99.

## References

- [1] J. R. Morrison and M. G. Egan, A new modulation strategy for a buck boost input AC/DC converter, *IEEE Trans. Power Electron.*, vol. 16, no.1, pp. 34 45, Jan. 2001.
- [2] H. Ma, Y. Ji, and Y. Xu, Design and analysis of single-stage power factor correction converter with a feedback winding, *IEEE Trans. Power Electron.*, vol. 25, no. 6, pp. 14601470, Jun. 2010.
- [3] H. Athab and D. Lu, A single-switch ac/dc fly back converter using a CCM/DCM quasi-active power factor correction front-end, *IEEE Trans. Ind. Electron.*, vol. 59, no. 3, pp. 15171526, Mar. 2012.
- [4] H. Ribeiro and B. Borges, High performance voltage fed ACDC full bridge single-stage PFC with reduced DC Bus capacitor, *IEEE Trans. Power Electron.*, vol. 29, no. 6, pp. 26802692, Jun. 2014.
- [5] M. Narimani and G. Moschopoulos, A three-level integrated AC/DC converter, *IEEE Trans. Power Electron.*, vol. 29, no. 4, pp. 18131820, Apr. 2014.



