

Community Experience Distilled

3D Printing Designs: The Sun Puzzle

Create a fascinating 3D printing-ready puzzle in no time!

Joe Larson

[PACKT] open source*
PUBLISHING community experience distilled

3D Printing Designs: The Sun Puzzle

Create a fascinating 3D printing-ready puzzle
in no time!

Joe Larson

[PACKT] open source 
PUBLISHING community experience distilled

BIRMINGHAM - MUMBAI

3D Printing Designs: The Sun Puzzle

Copyright © 2016 Packt Publishing

All rights reserved. No part of this book may be reproduced, stored in a retrieval system, or transmitted in any form or by any means, without the prior written permission of the publisher, except in the case of brief quotations embedded in critical articles or reviews.

Every effort has been made in the preparation of this book to ensure the accuracy of the information presented. However, the information contained in this book is sold without warranty, either express or implied. Neither the author, nor Packt Publishing, and its dealers and distributors will be held liable for any damages caused or alleged to be caused directly or indirectly by this book.

Packt Publishing has endeavored to provide trademark information about all of the companies and products mentioned in this book by the appropriate use of capitals. However, Packt Publishing cannot guarantee the accuracy of this information.

First published: June 2016

Production reference: 1140616

Published by Packt Publishing Ltd.

Livery Place
35 Livery Street
Birmingham B3 2PB, UK.

ISBN 978-1-78588-889-2

www.packtpub.com

Credits

Author

Joe Larson

Project Coordinator

Kinjal Bari

Reviewer

Marcus Ritland

Proofreader

Safis Editing

Commissioning Editor

Edward Gordon

Indexer

Hemangini Bari

Acquisition Editor

Vinay Argekar

Graphics

Kirk D'Penha

Content Development Editor

Shweta Pant

Production Coordinator

Shantanu N. Zagade

Technical Editor

Vishal K. Mewada

Cover Work

Shantanu N. Zagade

Copy Editor

Madhusudan Uchil

About the Author

Joe Larson, known online as "the 3D Printing Professor," is one part artist, one part mathematician, one part teacher, and one part technologist. It all started in his youth, doing BASIC programming and low-resolution digital art on a Commodore 64. As technology progressed, so did Joe's dabbling, eventually taking him to 3D modeling while in high school and college, and he momentarily pursued a degree in computer animation. He abandoned that and instead became a math teacher, and then moved to software development for 10 years before returning to education, teaching technology in college.

When Joe first heard about 3D printing, it took root in his mind, and he went back to dust off his 3D modeling skills. In 2012, he won a Makerbot Replicator 3D printer in the Tinkercad/Makerbot Chess Challenge, with a chess set that assembles into a robot. Since then, his designs on Thingiverse have been featured on Thingiverse, Gizmodo, Shapeways, Makezine, and other places. He currently produces weekly videos about design for 3D printing on his YouTube channel, <http://www.youtube.com/user/mrjoesays>.

About the Reviewer

Marcus Ritland is a designer and 3D printing consultant at his small business, Denali 3D Design. Since 2008, he has provided 3D modeling and 3D printing services, as well as moderating the SketchUcation 3D printing forum.

He has volunteered at a local makerspace, teaching SketchUp classes and leading 3D printing meetups. As an author of 3D Printing with SketchUp, he is currently on a quest to eliminate design-for-3D printing illiteracy.

www.PacktPub.com

eBooks, discount offers, and more

Did you know that Packt offers eBook versions of every book published, with PDF and ePub files available? You can upgrade to the eBook version at www.PacktPub.com and as a print book customer, you are entitled to a discount on the eBook copy. Get in touch with us at customercare@packtpub.com for more details.

At www.PacktPub.com, you can also read a collection of free technical articles, sign up for a range of free newsletters and receive exclusive discounts and offers on Packt books and eBooks.



<https://www2.packtpub.com/books/subscription/packtlib>

Do you need instant solutions to your IT questions? PacktLib is Packt's online digital book library. Here, you can search, access, and read Packt's entire library of books.

Why subscribe?

- Fully searchable across every book published by Packt
- Copy and paste, print, and bookmark content
- On demand and accessible via a web browser

Table of Contents

Preface	v
Chapter 1: 3D Printing Basics	1
What is 3D printing?	2
What defines 3D printing?	2
What to design for?	3
How do FFF printers work?	3
The anatomy of a print	4
FFF design considerations	5
Overhangs and supports	6
Supportless 3D printing	6
Y – gentle overhangs	7
H – bridging	8
T – orientation	9
Wall thickness	10
Holes in models	10
Summary	11
Chapter 2: Beginning Blender	13
Why Blender?	14
The price is right	14
Blender is comprehensive	14
It's getting better all the time	14
But Blender isn't perfect	14
Downloading and installing Blender	15
The default view	16
The 3D View	17
The 3D cursor	18

The best settings	19
A scroll-wheel mouse and number pad	20
A laptop with a touch pad and no number pad	22
Object creation	23
Navigating the view	24
Rotating the view	25
Jumping to rotation	26
Panning the view	26
Zooming the view	27
Orthographic versus perspective view	27
Wireframe and solid view	28
Transforming the object	29
Controlling transformations	30
Controlling the view	31
Axis locking	32
Precise transformation	34
Origin manipulation	35
Duplicating objects	36
Object selection	37
Shift select	37
Border select	38
Circle select	39
The Edit mode	40
Parts of objects	41
Incremental saving	42
Blender to real life	42
Exporting an STL	43
Summary	44
Chapter 3: Sculpting the Face of the Sun	45
Creating the base object	46
Setting up sculpt	48
Drawing the face	51
Smoothing the edges	57
Adding the nose and eyes	60
Pulling out the rays	65
Sharpening the details	70
Summary	76

Chapter 4: Cutting a 3D Jigsaw Puzzle	77
Resizing the model	78
How big should it be?	78
Scaling with properties	78
Building a puzzle piece	80
Building the basic shape	80
Sizing the puzzle piece blank	87
Turning a shape into an object	89
Adding some tolerance	91
Putting it all together	94
What if the Boolean modifier doesn't work?	98
Exporting and printing	99
Summary	100
Index	101

Preface

Sometimes, 3D printing needs to be precise and practical, and sometimes, it just needs to be fun. Like the wood-cut puzzles your grandpa may have made in his garage, 3D printing lets you make similar toys, but with a whole new dimension. Perhaps more than any other tool available, only Blender provides the combination of organic sculpting and robust geometric shape modeling together that makes such projects possible.

You will begin by learning the basics of designing for modern, economic, home 3D printers. Then, you'll learn what you need to know about the 3D modeling and animation tool, Blender, to get you started. Then, we'll start using Blender's sculpting tools to create a shape with actions as simple as drawing. Finally, we'll use Blender's shape-editing tools to make the basic puzzle shape and combine that with the sculpted model to create the final piece.

What this book covers

Chapter 1, 3D Printing Basics, will help you understand 3D printing basics, types of 3D printing, and how FFF printers work.

Chapter 2, Beginning Blender, will introduce Blender, how to set it up, and some basic and mid-level functionality. Knowing the content of this chapter will get you over Blender's famous learning curve and provide the basic knowledge and reference necessary for following along with future projects.

Chapter 3, Sculpting the Face of the Sun, teaches you how to use the sculpting tools in Blender to transform a basic shape into a complicated design.

Chapter 4, Cutting a 3D Jigsaw Puzzle, helps you prepare the model, followed by creating the puzzle space and then applying that to the model to create the individual pieces.

What you need for this book

A computer with at least a 2-GHz CPU, 2 GB of RAM, and, of course, Blender.

Who this book is for

This book is for anyone with an interest in home 3D printing and a desire to learn the basics of design along with the tools that can make their ideas a reality.

Conventions

In this book, you will find a number of text styles that distinguish between different kinds of information. Here are some examples of these styles and an explanation of their meaning.

Code words in text, database table names, folder names, filenames, file extensions, pathnames, dummy URLs, user input, and Twitter handles are shown as follows: Now, find `Ch10 Scanned Image.jpg`, and right-click to save the image.

New terms and **important words** are shown in bold. Words that you see on the screen, for example, in menus or dialog boxes, appear in the text like this: Start **Blender** and, as usual.

[ Warnings or important notes appear in a box like this.]

[ Tips and tricks appear like this.]

Reader feedback

Feedback from our readers is always welcome. Let us know what you think about this book – what you liked or disliked. Reader feedback is important for us as it helps us develop titles that you will really get the most out of.

To send us general feedback, simply e-mail feedback@packtpub.com, and mention the book's title in the subject of your message.

If there is a topic that you have expertise in and you are interested in either writing or contributing to a book, see our author guide at www.packtpub.com/authors.

Customer support

Now that you are the proud owner of a Packt book, we have a number of things to help you to get the most from your purchase.

Downloading the color images of this book

We also provide you with a PDF file that has color images of the screenshots/diagrams used in this book. The color images will help you better understand the changes in the output. You can download this file from https://www.packtpub.com/sites/default/files/downloads/3DPrintingDesignsTheSunPuzzle_ColorImages.pdf.

Errata

Although we have taken every care to ensure the accuracy of our content, mistakes do happen. If you find a mistake in one of our books – maybe a mistake in the text or the code – we would be grateful if you could report this to us. By doing so, you can save other readers from frustration and help us improve subsequent versions of this book. If you find any errata, please report them by visiting <http://www.packtpub.com/submit-errata>, selecting your book, clicking on the **Errata Submission Form** link, and entering the details of your errata. Once your errata are verified, your submission will be accepted and the errata will be uploaded to our website or added to any list of existing errata under the Errata section of that title.

To view the previously submitted errata, go to <https://www.packtpub.com/books/content/support> and enter the name of the book in the search field. The required information will appear under the **Errata** section.

Piracy

Piracy of copyrighted material on the Internet is an ongoing problem across all media. At Packt, we take the protection of our copyright and licenses very seriously. If you come across any illegal copies of our works in any form on the Internet, please provide us with the location address or website name immediately so that we can pursue a remedy.

Please contact us at copyright@packtpub.com with a link to the suspected pirated material.

We appreciate your help in protecting our authors and our ability to bring you valuable content.

Questions

If you have a problem with any aspect of this book, you can contact us at questions@packtpub.com, and we will do our best to address the problem.

1

3D Printing Basics

As cool as 3D printing is, there is a lot of hype around it, which sometimes causes confusion. Before starting to design for 3D printing, it's best to know a little bit about 3D printing technologies.

3D printing is a limitless technology in the sense that there is no end to the things it can make. Still, that doesn't mean that it can make anything without limitations. 3D printing can make things that no other manufacturing method can, but it has rules that need to be followed to ensure success. There are different types of 3D printing as well, and each type comes with its benefits and drawbacks:



In this chapter, we'll discuss:

- What is 3D printing?
- What types of 3D printing are there?
- How do FFF printers work?
- The anatomy of an FFF print.
- Supportless 3D printing and YHT.
- Wall thickness and tolerances.

What is 3D printing?

3D printing is cool. It seems as if not a day passes without another mention of 3D printing online in the news and media. Everyone is getting excited about 3D printing. But when you look deeper, it seems as if everything is being 3D printed, and anything could be. Does 3D printing something make it better? What exactly is 3D printing?

In many ways, 3D printers are just tools, the same as any that you'd find in a wood shop or garage. These tools make cool things, but not on their own, and just because something is made with, say, an electric drill press, that doesn't automatically make it better than something that isn't. It's the things that people, like you, are doing with these tools that make them cool.

I'm not saying that 3D printing isn't cool by itself. 3D printing lets you create things, test them, change their design, and try something new quickly until you get it right. It makes things of incredible complexity and, because it's additive manufacturing, generates comparatively little waste. The availability of cheaper and faster 3D printers means that there's a chance that there's a 3D printer near you.

What defines 3D printing?

There are many different types of 3D printers, but what makes them all similar is that they build solid shapes from layers of materials, starting with an empty build area and filling it with the print. This is called **additive manufacturing**, and it produces less waste than other techniques, such as starting with a base material that is cut away to make the thing.

3D printers also benefit from being computer-controlled machines, also known as **computerized numerical control (CNC)** machines, meaning they do what they do with minimal human interaction after the design work is done. They can make many identical copies of a thing one right after the other, and the design can be shared online so that others can make their own copies.

While all 3D printing shares some common features, there are several distinct types of 3D printing that vary in how they produce the print. **Fused filament fabrication (FFF)**, **powder bed**, or **light polymerization**, for example, all accomplish 3D printing in very different ways, and each with their own strengths and weaknesses. What works in powder bed 3D printing might not work with FFF 3D printing, and the part you get from light polymerization might not be suitable for the same usage as those made with the other techniques.

What to design for?

It is the best practice to always design towards the strengths and weaknesses of the medium you'll be using. The projects in this series of books will focus on designing for FFF 3D printers, because they're inexpensive and more readily available than the others, and the parts made with FFF 3D printers are suitable for a wide variety of functional uses. Also, many of the techniques for FFF design transfer to the other types of 3D printing. But because FFF 3D printers have limitations, there will be some things you need to know first.

How do FFF printers work?

There tends to be a lot of variation within the family of FFF 3D printers. Some have their mechanisms exposed to the environment so that they're easy to repair, while some are protected with fancy covers so that they look good. Some have one extruder, while some have two or more. Some have fancy interface screens, and some require you to use a computer to access even the most basic functions. Yet, for all their variations, there are many similarities that all FFF printers share which define their type. Being familiar with how FFF 3D printers work will help you guide yourself while designing for them.

For FFF 3D printers, a computer takes a 3D model and translates it into commands that the printer can follow. The printer then takes a roll of plastic filament on a spool and uses a feeder mechanism to feed it into the hot end, where the plastic filament is melted and squirted out at a controlled rate onto the print bed, where the print is built up. The extruder head and print bed are moved relative to each other in 3 dimensions, using some sort of movement system in order to create the 3D model:

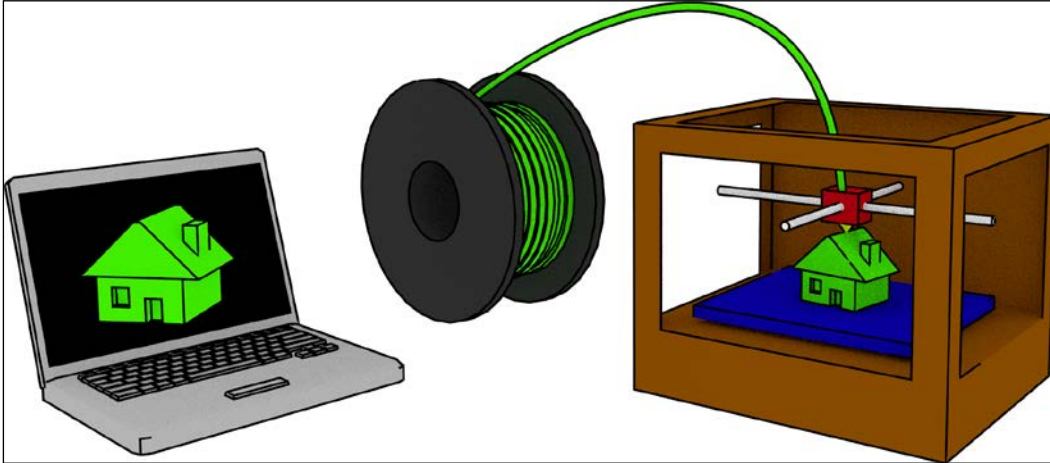

Drawing a print layer by layer like this takes, as might be expected, a little bit of time. The larger the object, the longer a print will take. FFF 3D printing isn't a fast process. But once the process is done, a new thing will have been created.

The anatomy of a print

Now that the mechanics of FFF 3D printing are clear, it's time to take a look at how a print is built. If an FFF print is stopped partway through, or observed during printing, the following can be seen:

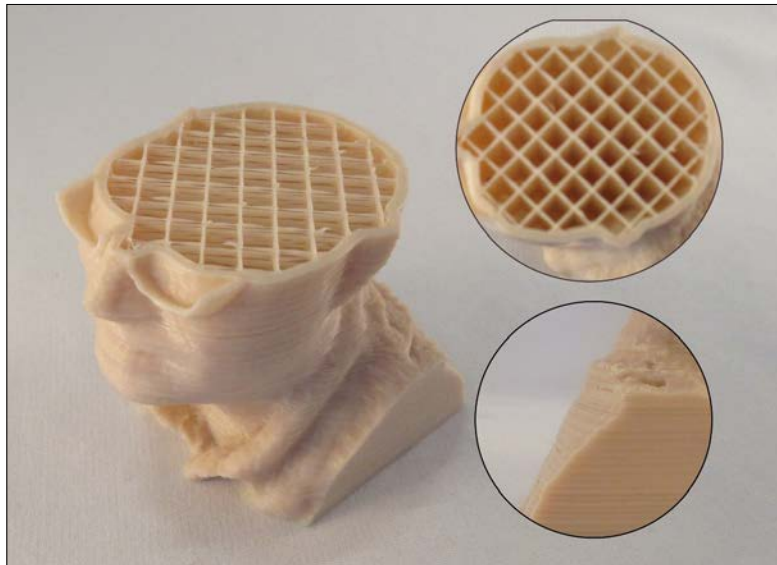

The following are the different parts shown in the preceding image:

- **Layers:** FFF prints in layers, with each layer sitting on the one below it. Prints can be made with thicker layers so that they print faster or thinner layers so that they look better.
- **Outlines:** When starting a layer, the outline of that layer will usually be printed first. FFF prints often have two or more outlines so that the outside of the print is strong.
- **Infill:** once the outline is done, the rest of the layer is filled in. If an area of the print will not be seen from the outside when the print is done, a loose infill is used to save material and give layers above something to sit on. Top layers are filled in completely. Most FFF prints are largely hollow.

FFF design considerations

The basic limitations of FFF printers stem from the fact that most FFF 3D printers are developed by people who have very little accountability. To the people creating and manufacturing these printers, if the printer can print a thing most of the time, then that's probably good enough. In this way, FFF printers are more like garage tools than desktop machines. For those unfamiliar with FFF printers, there are some drawbacks that need to be taken into account.

Overhangs and supports

FFF 3D printers have to worry about overhang. Overhang is when a part of the design, when it prints, will not have anything between it and the build platform. To compensate for this, the 3D printer can build a lattice of support material up to the overhanging part. After the print, the support material will have to be removed. But since for most FFF 3D printers the support material is made of the same material as the object, it can rarely be removed without a trace that is sometimes difficult to clean up completely and can leave a mess on more complex prints:



Because of the troubles with supports, it's a good idea to design for supportless 3D printing.

Supportless 3D printing

Think about building a snowman or sand castle. There's a lot that can be done with the medium of sand or snow, but try to get too fancy with the design and it will fall apart. As long as every part is sitting on top of something, chances are it will hold together. You could even slope gently outwards, as long as you don't push it too far.

It's the same with 3D prints. Because it prints in layers, each layer needs to have something to lay down on. If a design is made so that a part has nothing underneath it and is dangling in the air, then the printer will still extrude some plastic to try to print the part, but with nothing to print on, the plastic will just drool from the extruder until it gets wiped off on some other part, making an ugly mess and ruining the print.

As long as you put some thought into it, you can make designs that will succeed in most cases. There are a few rules that can help, and these rules can be illustrated with the letters Y, H, and T.

Y – gentle overhangs

Think about 3D printing a capital letter Y, standing up on the build platform – something like this:

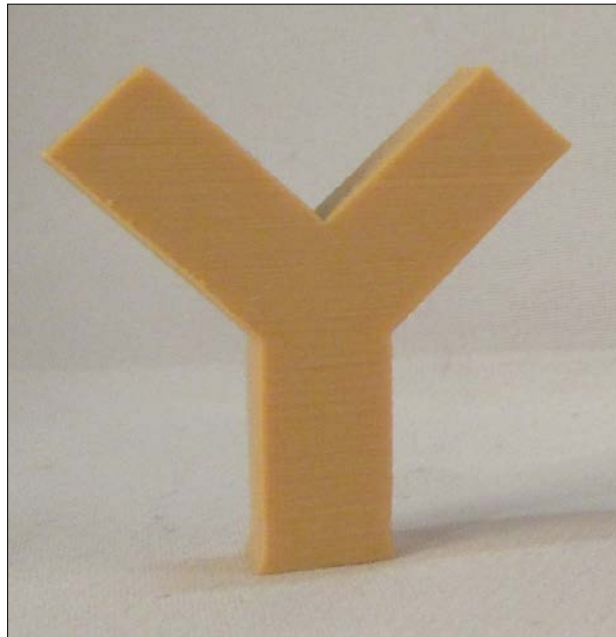

As the print gets to the part where the arms of the Y branch out, the change is gradual. It is possible to have the current layer slightly larger than the previous one, provided the overhang is gentle. Generally, a 45-degree overhang is safe. Hence, a shape like the letter Y will successfully print standing up.

However, if the overhang is too great or too abrupt, the new layer will droop, causing a print to fail. Some 3D printer owners pride themselves in pushing their overhang and have seen success with angles as steep as 80 degrees, but to be safe, keep your angles no more than 45 degrees.

H – bridging

If a part of the print has nothing above it but has something supporting it on either side, like a capital letter H standing up, then it may be able to bridge the gap when printing:



Use caution when bridging. The printer makes no special effort when making bridges; they are drawn like any other layer: outline first, then infill. As long as the outline has something to attach to on both sides, it should be fine. But if that outline is too complex or contains parts that will print in midair, it may not succeed. Being aware of bridges in the design and keeping them simple is the key to successful bridging. Even with a simple bridge, some 3D printers need a little bit more calibration to print it well.

Hence, a shape like the capital letter H will successfully print most of the time because of bridging.

T – orientation

If you were to try to print a capital letter T standing up on the build platform, you would surely run into problems:



The top arms have far too much overhang to print successfully. Of course, the solution to this is simple: when designing, flip the T over or lay it down. In fact, every letter of the alphabet will print successfully if laid on its back, but the letter T illustrates this best. Sometimes, when designing a part for 3D printing, it's good to turn it around and orient it so that it prints well. Not every print needs to be printed in the same way it's going to be used.

Wall thickness

There is a minimum size of things that a 3D printer can print. This size is determined by the size of the hole in the nozzle, called the nozzle diameter. The most common nozzle diameter is 0.4 mm; however, most printers will not print a wall with a single extrusion thickness. They require that a wall be at least as thick as two nozzle widths, which in most cases means walls need to be at least 0.8 mm. However, because of the way slicers calculate outlines, 0.8 mm isn't just a minimum wall thickness – it's a target. For instance, if the wall is 1 mm thick, it won't be able to fill in the gap between the outlines, and there will be an air pocket. And while 0.4 mm is a very common nozzle diameter, it is not the only nozzle diameter, so a 0.8 mm wall may still be too thin for some 3D printers.

For thickness, it's best to err on the side of caution. A 2 mm wall is thick enough that slicers can use one or two outlines without conflict and still have room for a little infill, no matter the nozzle diameter. This will make solid prints that will succeed in almost all cases, and 2 mm is still fairly thin, allowing for considerable detail. Unless you are designing for a specific printer or planning to share your model with others, always make your walls a minimum of 2 mm thick to be safe.

Holes in models

Models for 3D printing must be closed, that is to say, they must have no holes in them. In a classic cartoon, there was a scene where bubbles were blown, but they were not bubble shaped. They were square, squiggly, and pink-elephant shaped. But no matter their shape, they were still bubbles. If a hole developed in them, they popped. In the same way, models for 3D printing cannot have holes:

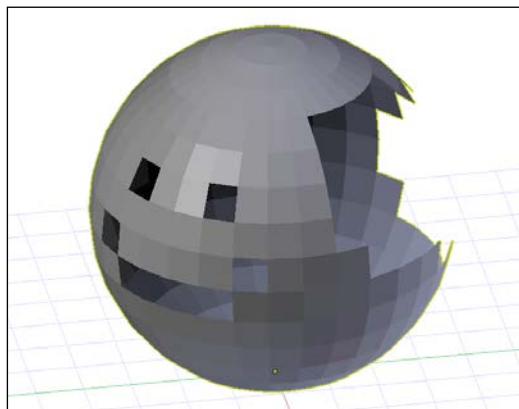

In mathematical terms, holes in models are included in a family of errors called non-manifold. Models for 3D printing must be manifold or else the slicer will have trouble telling what is supposed to be the inside and outside of the model.

In the same vein, a wall by itself, without an inside or outside, isn't printable because a 2D wall has no thickness and doesn't describe a shape that can exist in real life. 3D prints must be part of a three-dimensional shape with a thickness, as described in the previous section.

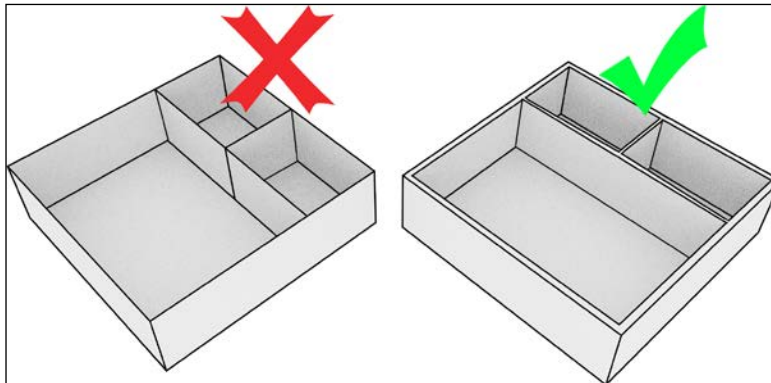

Summary

3D printing is cool and allows the creation of fantastic and detailed objects without needing much interaction with people after the design is done. But designing for 3D printing is a lot like designing for any other type of manufacturing. It helps to know a bit about the process involved and design with that process in mind.

Fused filament fabrication 3D printing, or FFF for short, is one of the oldest, most mature, and cheapest forms of 3D printing, so this series will focus on designing for it. It involves melting a plastic filament and drawing the object layer by layer, with each layer sitting on top of the one below it.

Designing for the most effective FFF printing means thinking about overhangs and supports and about the parts of the prints that don't have anything underneath them when they print. To avoid needing supports when printing, it can help to remember the letters Y, H, and T when designing, in order to remember to consider gradual overhangs, bridging, and orientation. In addition, it's important to remember that details should be, generally, about 2 mm thick.

Now that the mechanics of 3D printing and how they affect design have been covered, the next chapter will deal with the specific software that will be used in this series.

2

Beginning Blender

3D printers need 3D models to print. Those models don't just come out of nowhere. You will need imagination, a little time, and software to create 3D models for the things you want to print. Never have there been more software options for creating 3D models – professional and free options. In this series, the software of choice is called Blender.

This chapter will introduce Blender, how to set it up, and some basic and mid-level functionality. Knowing the content of this chapter will get you over Blender's infamous learning curve and provide the basic knowledge and reference material necessary to follow along with future projects. We'll cover these topics:

- Why Blender?
- Downloading and installing Blender
- The default view
- The best settings
- Object creation
- Navigating the view
- Transforming
- Controlling transformations
- Selecting
- The edit mode
- Blender to real life
- Exporting an STL

Why Blender?

With so many options for 3D modeling software, why would Blender, a software designed to make 3D animations, be the most popular choice?

The price is right

First things first: you don't have to pay for Blender. It is offered free of charge. If it works for you, you always have the option to donate, but Blender doesn't do anything to force this point. It is free now and forever.

Blender is comprehensive

While it's true that Blender is designed for animation because it covers everything from a blank canvas to a finished animation, it contains the ability to model objects, and it's one of the most robust suites of modeling tools anywhere. Learning Blender means that you may never need to learn another 3D modelling software.

It's getting better all the time

Blender is in constant development. If it doesn't have a feature you need, chances are that it may one day. Blender's developers are constantly responding to their audience.

But Blender isn't perfect

Despite Blender's advantages, it has a well-earned reputation for having a difficult-to-overcome learning curve. It's had a long and organic development cycle, which left it with a default user interface that isn't intuitive compared to most other software.

But Blender is also very configurable and, with a few simple settings, it can be made much easier for the beginner to use. The rest of this chapter will help get you past Blender's short comings so that you can start developing awesome 3D models.

Downloading and installing Blender

The first thing that needs to be done is downloading and installing Blender. Follow these steps:

1. On your PC or Mac, open a your web browser and go to <http://www.blender.org>.
2. Locate the **Blender** download button on the main page for the latest version of Blender and click on it:

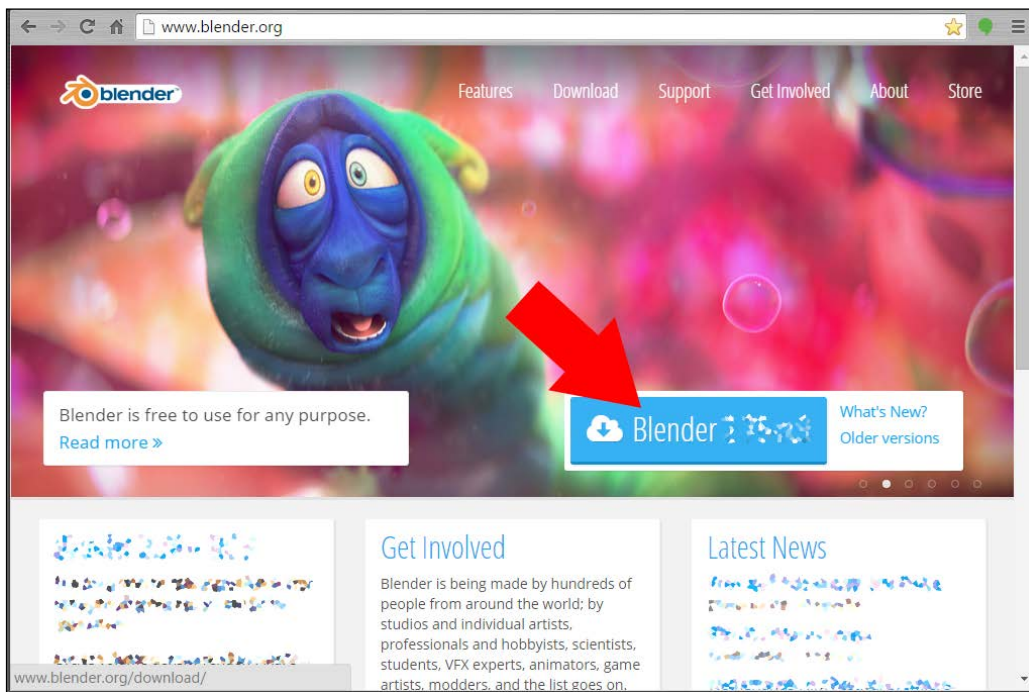



3. Scroll down and find **Download** under **Blender** and click on it. If you're on Windows and unsure, just choose the MSI package option.
4. When the installer finishes downloading, run it.
5. Follow the prompts to install **Blender**.
6. When the installer is finished, run **Blender**. Click anywhere to close the splash screen.

Blender is now installed and ready to use.

The default view

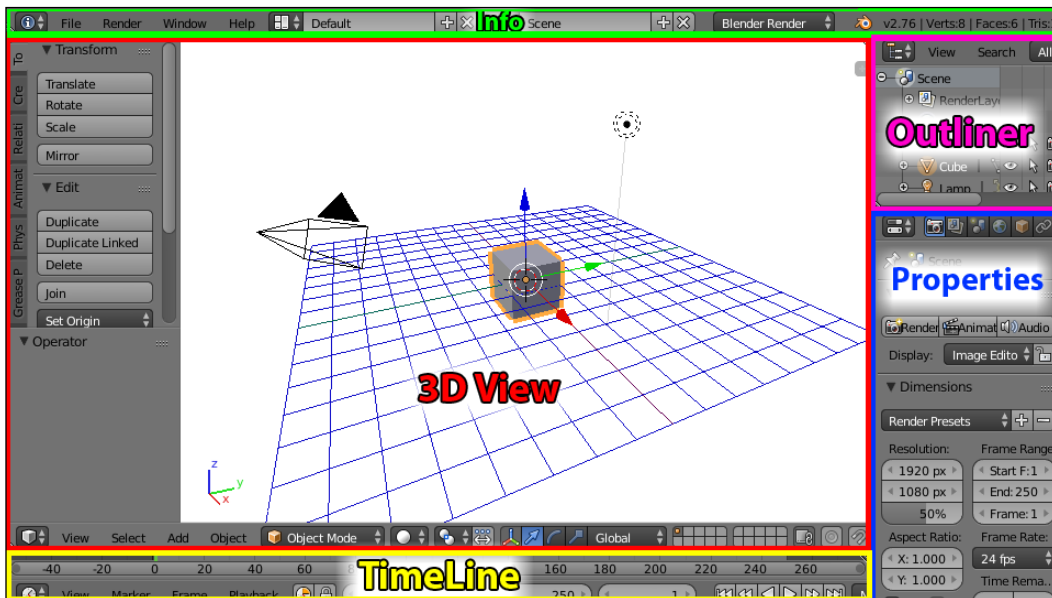
Blender's interface is made up of many smaller windows called **panels**. There are many different panels available in Blender. Like most things in Blender, the panels are completely configurable. Panels can be added or removed as needed, and panel layouts can be saved and switched among easily. For simplicity, the default view – the way Blender is presented the first time it loads up – will be used throughout this series. It provides most of the necessary functionality:



 For the most part, the screens shown in this book series will look similar to the default Blender screen. The major change will be to the background color of the 3D View, a choice made to make the illustrations more compatible with printing.

Here's an explanations of the different panels in the default view:

- **The Info panel:** Located across the top of the window, the **Info** panel has many of the menu options in most programs, such as **File**, **Window**, and **Help**. It also has **Layout** settings, **Scene** settings, and **Renderer** options, but we won't be using them much. Finally, there are specific details about the version of Blender, the current scene, and selected objects. If the **Info** panel is cut off, bringing the mouse pointer over to the panel and using the scroll wheel will bring the information into view.

- **The Outliner:** Located in the upper-right section of the window, the **Outliner** contains the list of all objects.
- **The Properties panel:** Located in the lower-right section of the window, the **Properties** panel is broken into many tabs related to the currently selected object. Which tabs and properties are available will change depending on what is selected. If the tabs are cut off, bringing the mouse pointer over them and using the scroll wheel will bring them back into view.
- **The Timeline:** This panel is largely unnecessary for the purposes of this book series, so it can be removed or ignored.
- **The 3D View:** Taking up most of the screen, the **3D View** is where most things will be happening, and it consists of many smaller parts itself.

Each of the panels has its own keyboard shortcuts. In order to use them, the mouse pointer must be over the panel. If a keyboard shortcut isn't working, it's probably because the mouse pointer isn't in the right place.

The 3D View

Because it's so complex and important, the **3D View** will be given some special attention.

The **3D View** is where most of the action takes place, and it has the most visual feedback of the work. The **3D View** has its own menus and panels:

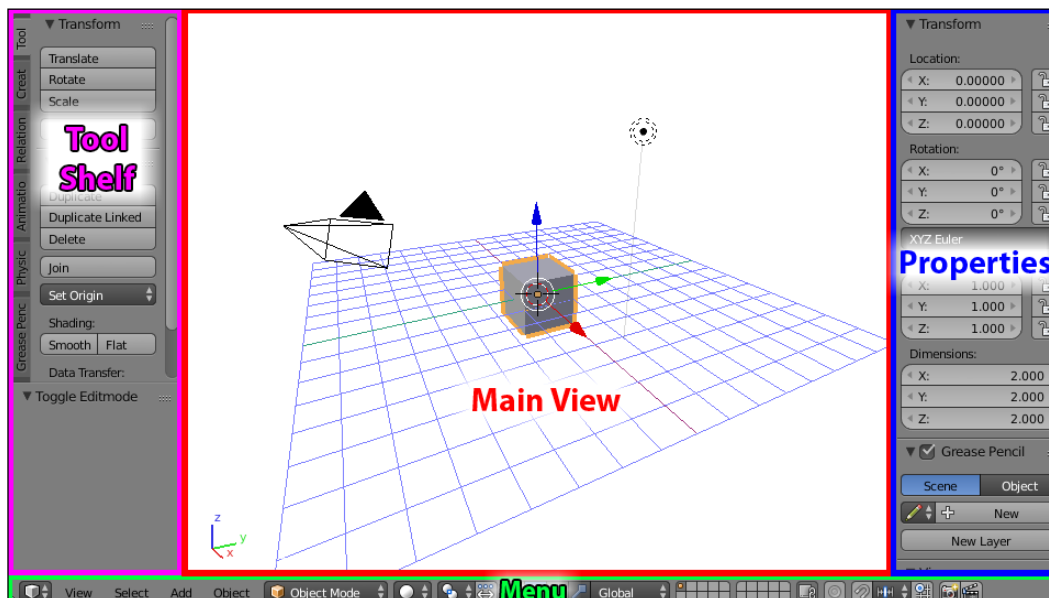

Here's what the panels do:

- **Menu:** At the bottom of the **3D View** is its **Menu**. It contains options and commands specific to the **3D View**. If the menu is cut off, bringing the mouse pointer over the panel and using the scroll wheel will bring the cut-off information into view.
- **Tool Shelf:** On the left-hand side is the **Tool Shelf**. It contains a tabulated set of buttons that can be used to do many useful things and change depending on the object selected. The bottom half of the **Tool Shelf** contains operator options. Any time an operation is performed, this area will be populated with options for that operation that can be edited until the next operation is performed. The **Tool Shelf** can be hidden or revealed by using the **3D View** menu and selecting **View | Tool Shelf** or by pressing *T* key on the keyboard.
- **Properties:** On the right-hand side is the **Properties** panel. Hidden by default, this panel contains information about the currently selected object as well as other options about the scene in general. The panel can be hidden or revealed by using the **3D View** menu and selecting **View | Properties** or by pressing *N* key on the keyboard.
- **Main View:** Of course, in the middle is the view of the current scene with all the visible objects.

The 3D cursor

In the **3D View**, there is a little red-and-white circle that starts in the middle of the 3D space. New objects will be created wherever the 3D cursor is located, and it's very easy to move the 3D cursor accidentally, so it'd be good to know how to put the 3D cursor back in the middle and how to move it on purpose. The 3D cursor can be manipulated by:

1. Clicking the right mouse button in the **3D View** to move the 3D cursor wherever it is clicked in a plane relative to the view, which can be unpredictable.

2. Navigating to **View | Align View | Center Cursor and View All** or pressing *Shift + C* on the keyboard while in the **3D View** to put the 3D cursor back in the middle quickly. This is the easiest way to fix the 3D cursor if it gets moved unexpectedly.

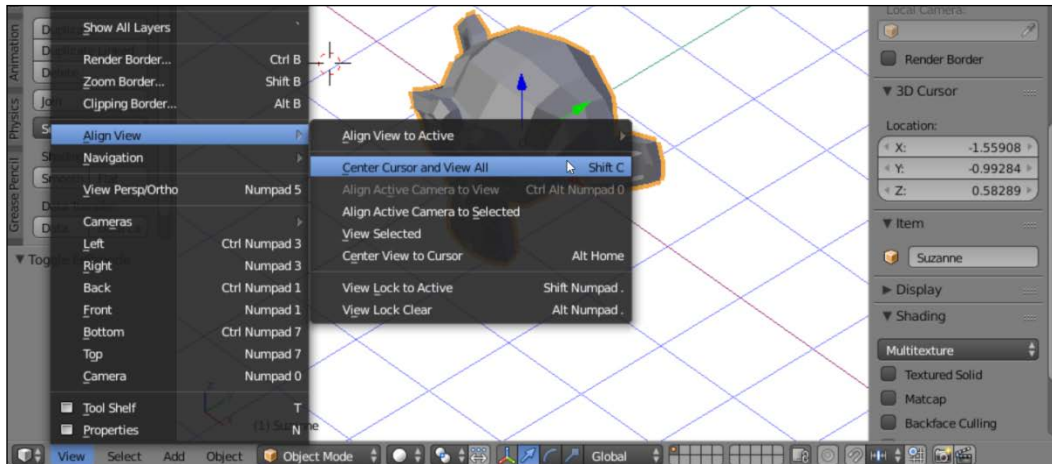

3. Typing the 3D cursor's *x*, *y*, and *z* coordinates in the **3D View** properties.

The best settings

Blender has a reputation for being difficult and unintuitive to use. This is true for the default settings. However, Blender is also very easily adjustable with a few settings and can be made much easier to use. How you set up your instance of Blender will depend on what your setup is like.

To access the settings, in the top menu select **File | User Preferences**. In the Blender **User Preferences** panel that comes up, select the **Input** tab button:

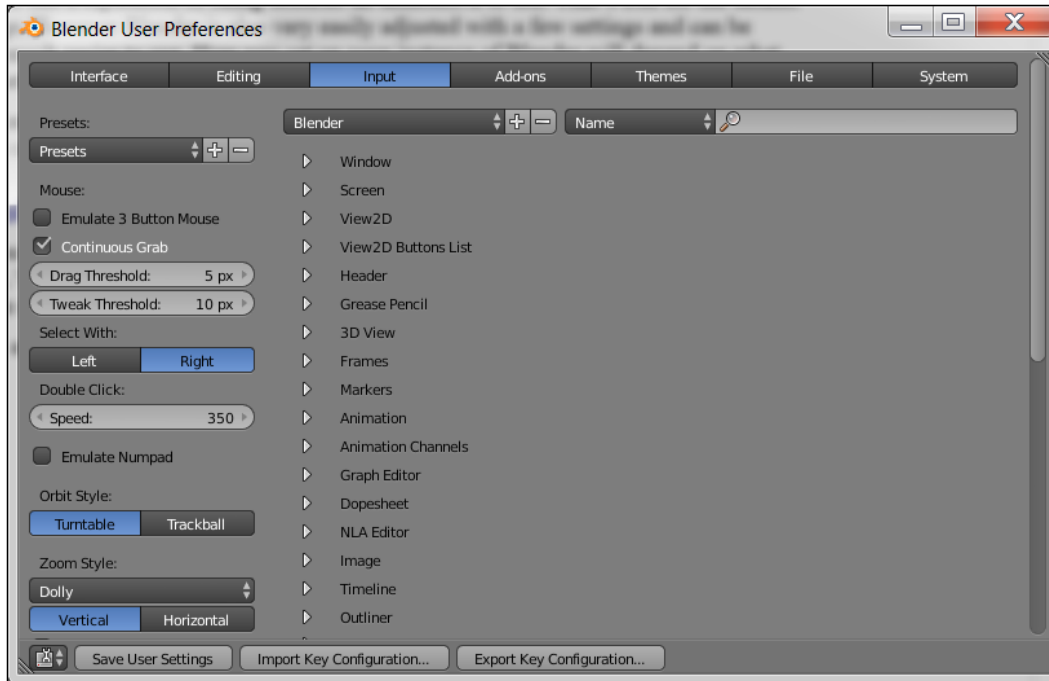

A scroll-wheel mouse and number pad

The recommended setup for Blender is to use your keyboard and a mouse with a scroll wheel. In this case, there is only one setting that is recommended to be changed from the default:

1. Click on the button that says **Left** under the words **Select With**.
2. Click on the button that says **Save User Settings**:

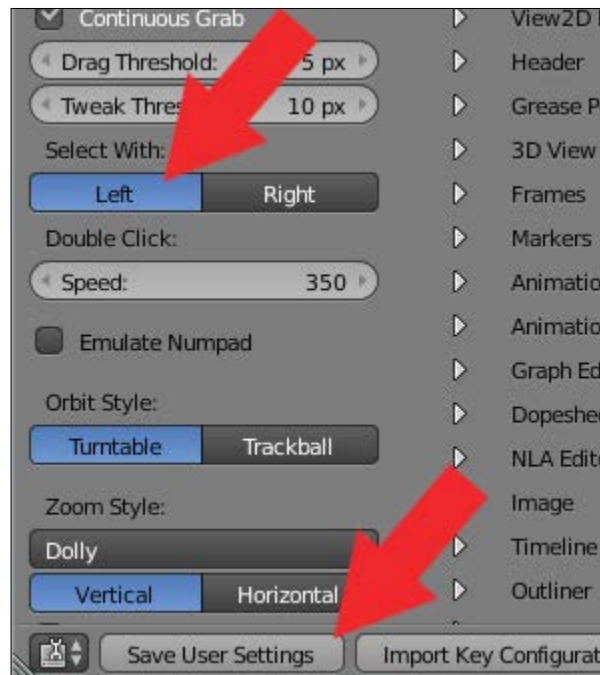

Changing this one setting will make Blender much more intuitive to use.

Because the default is for the right mouse button to be the select button, and some may prefer to keep this default, this book will refer to whatever option is chosen as the select mouse button, and the other button as the not-select mouse button. While still a bit confusing, it will help users who miss this section.

With a scroll-wheel mouse, the scroll wheel can be depressed for a middle mouse button click. Blender uses this middle mouse button to manipulate the view.

If you have a Numpad but no scroll-wheel mouse, it is still recommended to use these settings because the interface will be much more intuitive, although you will be sacrificing some functionality that the middle mouse click offers. The choice is yours whether it's worth having a more intuitive interface.

A laptop with a touch pad and no number pad

On a laptop with a touchpad (with no middle click) and no number pad, both very important for navigating the view, select the following settings:

- **Emulate 3 Button Mouse**
- **Emulate Numpad**
- Click on the button that says **Save User Settings**

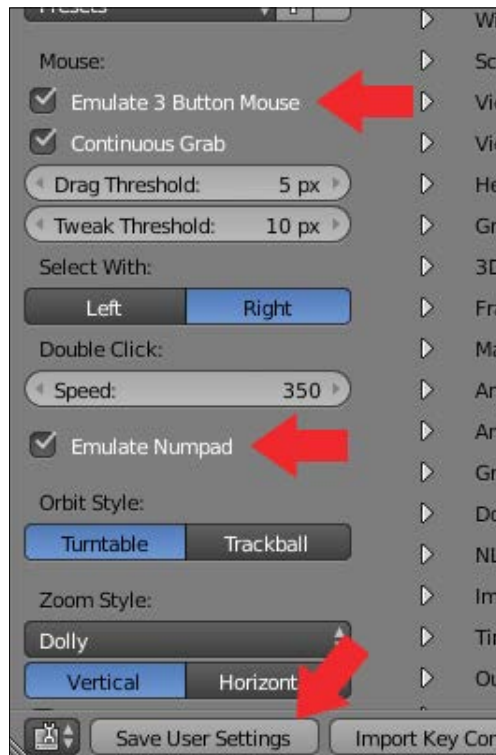

With this setup, most of Blender's functionality is available to laptop users, although these settings are less intuitive. With these settings, you will need to use the right mouse button to select objects, *Ctrl* + right mouse button as a middle mouse button to change the view, and the number keys across the top will perform the function of the number pad on a regular keyboard.

With Blender set up, it's time to start learning to use it. Close the **User Preferences** window.



Blender users tend to use keyboard shortcuts for almost everything. It's recommended that you use Blender with one hand on the mouse and the other on the keyboard. Learning and using keyboard shortcuts will speed up your process and, with just a little practice, will become second nature. Going forward, all methods of accessing commands will be taught. Try to practice using the keyboard shortcuts.

Object creation

Most tutorials for Blender start with navigating the **3D View**. But in Blender, the default scene is kind of boring for this, just a cube that looks the same from every angle. Instead, let's make something more interesting to look at.

First, let's look at how to clear the default scene:

1. Select all the objects in the scene by going to the **3D View** menu and choosing **Select | (De)select** all twice or pressing the *A* key twice. Everything in the scene should have an orange line around it. If not, do it again.
2. Delete everything by going to the **3D View** menu and choosing **Object | Delete** or pressing the *X* key.

Your **3D View** should now have nothing but the grid, which can be thought of as the floor of the scene.

To create an object, go to **3D View** menu, choose **Add** or press *Shift + A*.

In the menu that pops up are all the basic objects that can be inserted into the scene. Blender offers many basic shapes that can serve as a starting point for anything you want to create. Sometimes, a basic object is all you need, and sometimes, the basic object needs to be modified.

In this case, add a **Monkey** object to the scene:

1. In the **3D View** menu, choose **Add** or press *Shift + A*.
2. Select **Mesh | Monkey** in the menu that appears.

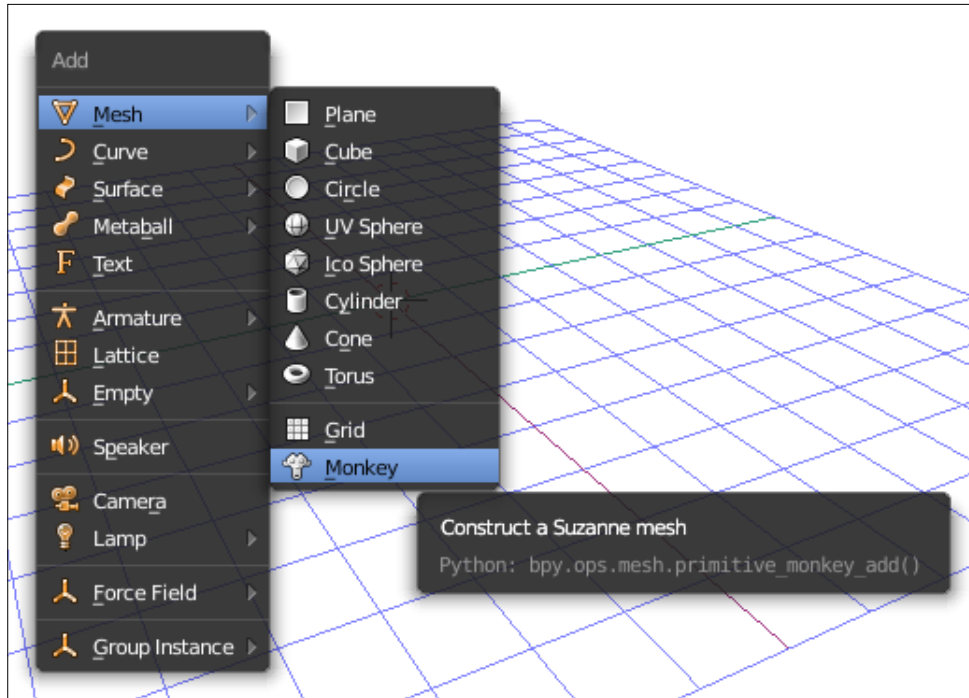

The **Monkey** object is good when learning to navigate the view because it's easy to see which way it's facing, no matter how the view changes. So, with a monkey object in the scene, it's time to learn how to change your perspective.

Navigating the view

Because Blender is all about working in 3D, but computer screens are flat, it is important to know how to change how you're looking at something in Blender.

 All of the following commands can also be found in the **3D View** menu under **View | View Navigation**; however, since adjusting the view happens so frequently, it is recommended to learn the mouse and keyboard shortcuts instead of navigating menus to do this.

Rotating the view

In Blender, you can change the angle of the view by:

- Clicking and holding the middle mouse button and moving the mouse pointer.
- Pressing 2 or 8 on the number pad to rotate the view up and down.
- Pressing 4 or 6 on the number pad to rotate the view left and right.

The point at which the view is rotating can change. Follow these steps to center the view rotation on a specific object:

1. Select the object.
2. Press the . (period) key on the number pad.

The selected object will fill the view and all view rotations will now center on that object:

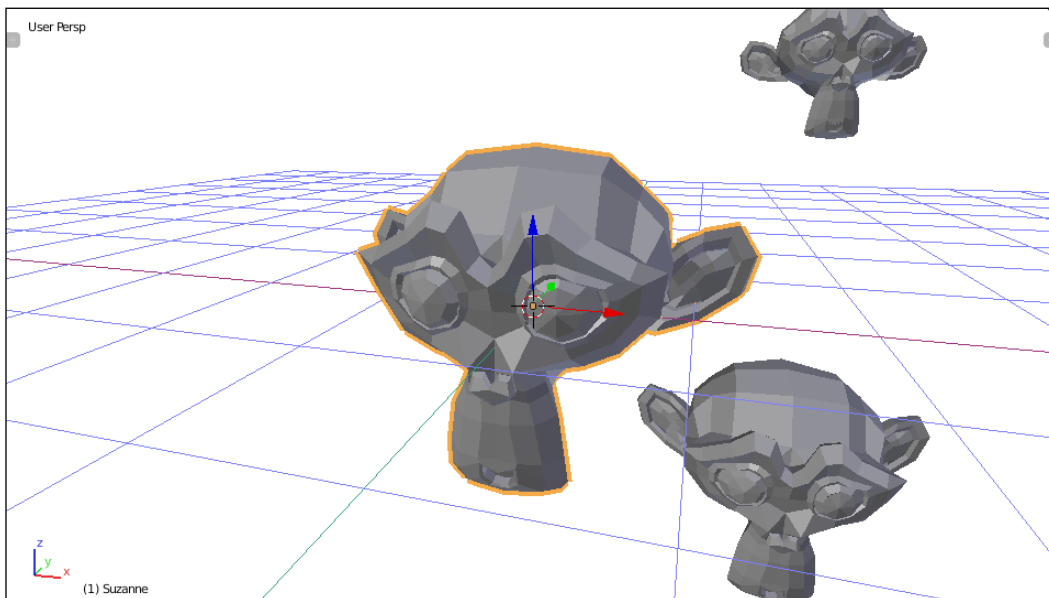

Jumping to rotation

Blender has six set views that can be quickly jumped to at any time:

- Press *1* on the number pad to jump to the front view
- Press *3* on the number pad to jump to the right view
- Press *7* on the number pad to jump to the top view
- Press *Ctrl + 7* or *9* on the number pad to jump to the bottom view
- Press *Ctrl + 1* on the number pad to jump to the back view
- Press *Ctrl + 3* to jump to the left view

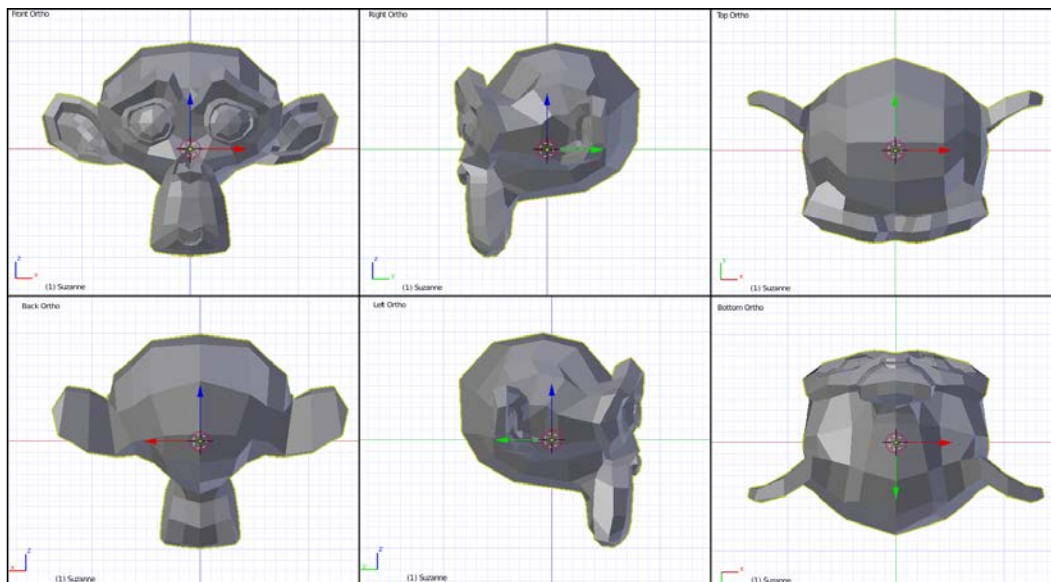

Panning the view

Panning the view means moving without changing the rotation, like moving your head while it's still pointed in the same direction. To pan the view, follow these steps:

- Press *Ctrl + 4* on the number pad to pan left
- Press *Ctrl + 6* on the number pad to pan right
- Press *Ctrl + 8* on the number pad to pan up
- Press *Ctrl + 2* on the number pad to pan down
- Hold *Shift* while clicking and holding the middle mouse button and move the mouse



Panning the view is one of the functions that changes the center of rotation. Remember: you can reset the center of rotation by selecting an object and pressing . (period) on the number pad.

Zooming the view

Zooming the view is moving closer to or farther from the object. To zoom the view, do one of the following:

1. Turn the scroll wheel.
2. Press Ctrl + middle mouse button and move the mouse.
3. Press + or - on the number pad.

Orthographic versus perspective view

To toggle between orthographic and perspective views, press 5 on the number pad.

The words **Persp** or **Ortho** can be seen in the upper right-hand corner of the **3D View**, indicating which view is being used:

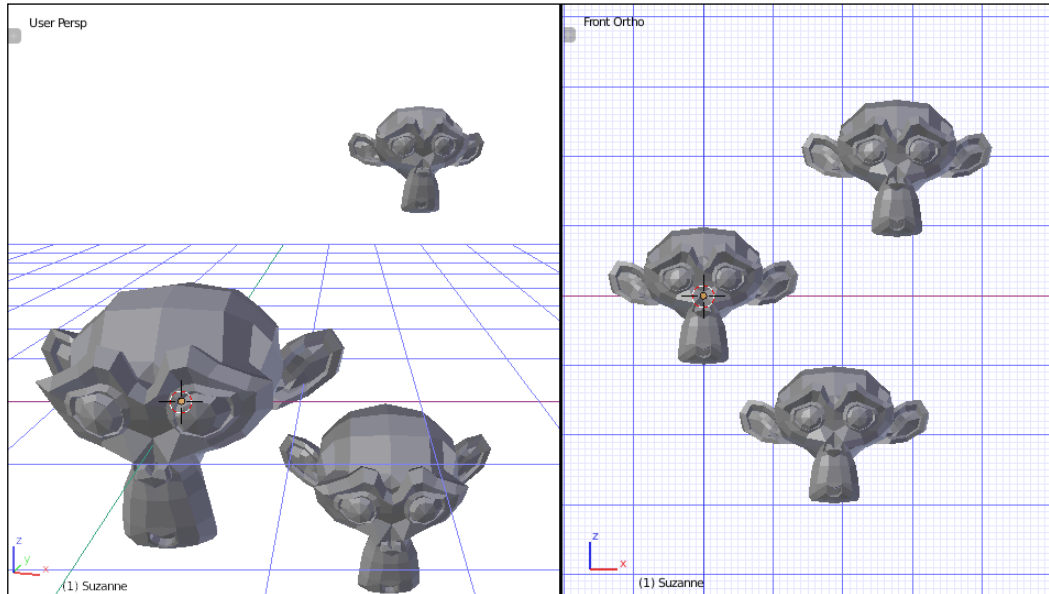

There are two ways of looking at the **3D View** on a computer. Perspective is the default, and more closely resembles how things will look when viewed through a camera or our eyes: closer objects look bigger; farther objects look smaller. Orthographic makes everything the same size, no matter how close or far it is. This makes it easier to compare objects and determine their location relative to one another.

Because a lot of 3D modelling requires precision, orthographic is generally preferred; however, it can be confusing when two objects overlap exactly. For this reason, it's good to adjust the view frequently and be sure that the action you're performing is the action you think you're performing.

Wireframe and solid view

With 3D modelling tools, it helps to be Superman. Being able to see through objects can help when selecting and modelling things. You can switch between the **Wireframe** and **Solid** views using one of these methods:

1. Press Z to toggle between **Solid** and **Wireframe** view.
2. On the **3D View** menu, click on the **Method to Display** popup and choose **Solid** or **Wireframe**.

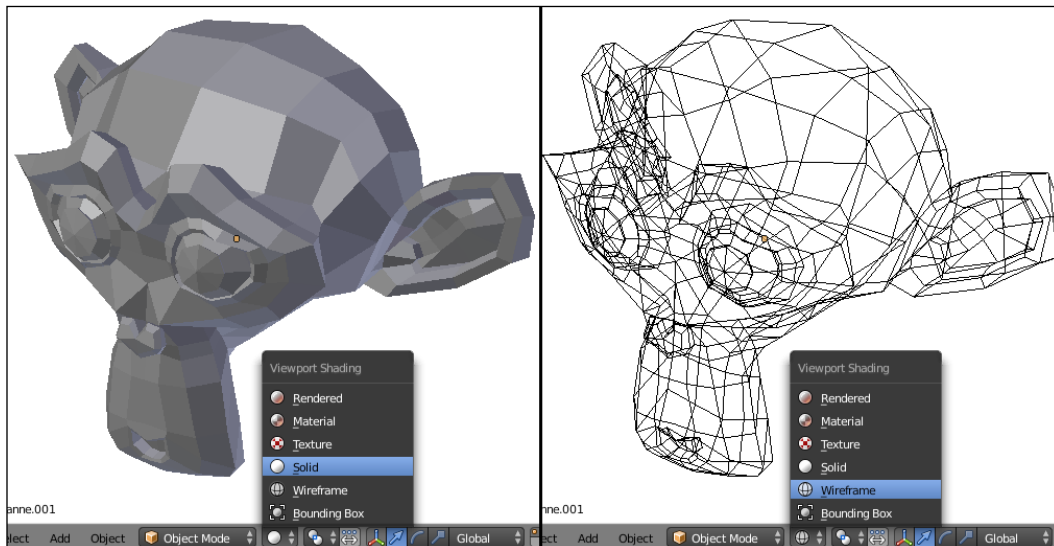

Wireframe mode is very powerful, especially in **Edit** mode, but it can be very confusing, especially as objects get more complex. **Wireframe** mode allows objects behind the objects in the foreground to be selected without adjusting the view. Get used to switching between **Solid** and **Wireframe** mode frequently.

Transforming the object

In Blender, transforming an object changes the size, direction, or location of a thing without changing its shape. There are three basic transformation commands that are used frequently: *Grab and Move*, *Rotate*, and *Scale*.

To transform an object, be sure the object is selected, and then, from the **3D View** menu:

- Select **Object** | **Transform** | **Grab/Move** or press *G* on the keyboard to move the object
- Select **Object** | **Transform** | **Scale** or press *S* on the keyboard to scale the object
- Select **Object** | **Transform** | **Rotate** or press *R* on the keyboard to rotate the object

Then, move the mouse or use the arrow keys to transform the object. When the transformation has been accomplished, press *Enter* or the select mouse button to end the operation, or the transformation can be cancelled by pressing the not-select mouse button or the *Esc* key. The following diagram shows these object transformations:

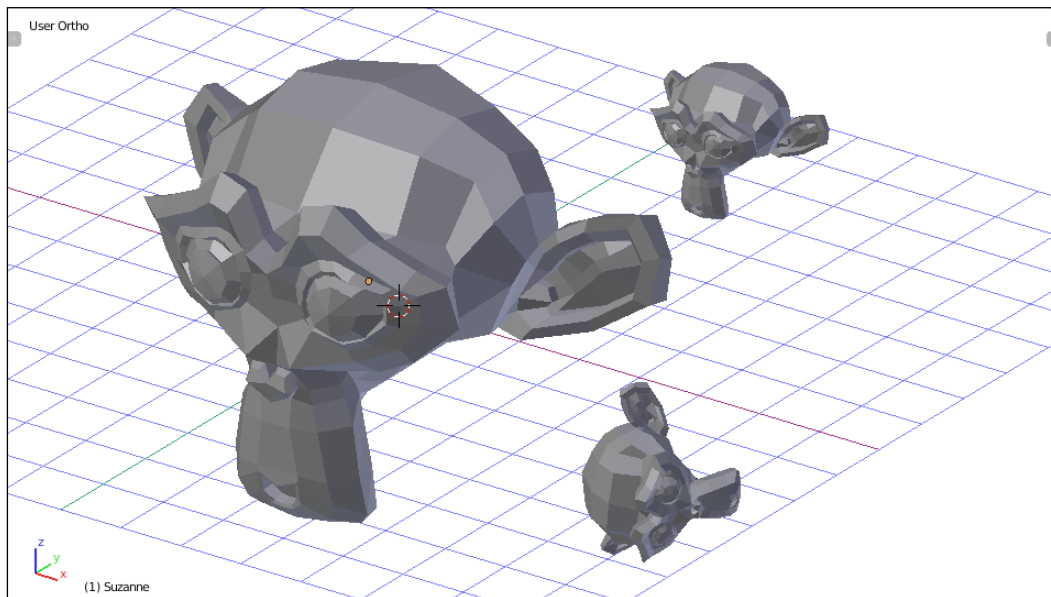

Transformations can also be undone after they're completed by pressing *Ctrl + Z*.



Transform the **Monkey** added to the scene by moving, rotating, and scaling it. Get a feel for how these commands work. Then, try to move the **Monkey** to a specific place in the scene. When you think you have it, change your view to see whether it's really where you think it is.

Controlling transformations

By default, operators in Blender operate on a 2D plane tangential to the view. This is a fancy way of saying that without any additional controls, it can be hard to predict how a movement or rotation operation will work. For instance, moving something in a random view can include moving up and down more than expected. This effect won't be clear until the view is changed and the transformation is inspected from a different angle, as shown here:

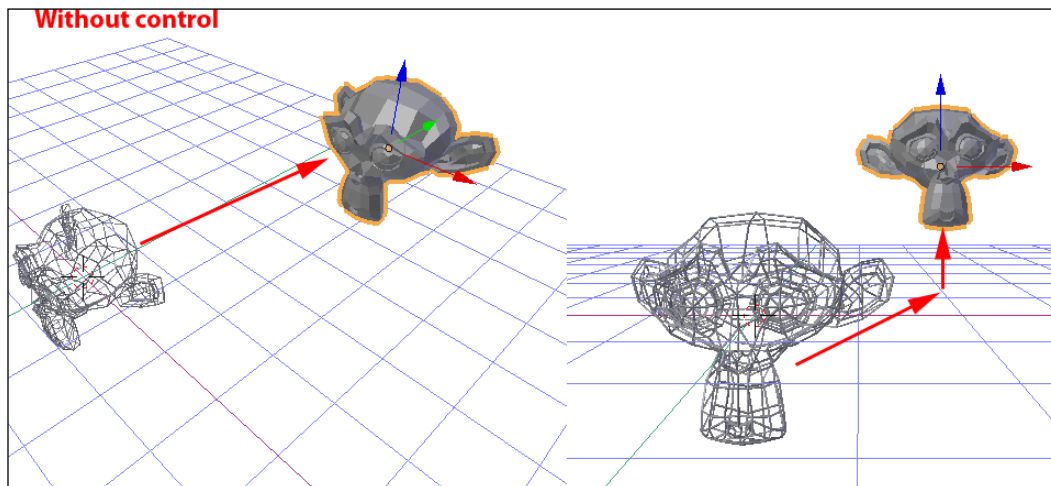

If you can't predict how operations will work, it can be hard to make the things you want. So it is very important to be able to control transformations.

There are two main ways of controlling operators: **controlling the view** and **axis locking**.

Controlling the view

The first way to control the operation is by controlling the view. By default, operators depend on the view, so by controlling the view, you can control the action. For instance, an object, when added to a scene, is exactly halfway through the grid plane of the world by default. If you want to make sure the object stays halfway through the grid plane when moving, follow these steps:

1. Select a newly added object.
2. Switch to **Top Ortho** view by pressing 7 on the number pad.
3. Grab and move (G) the object around.

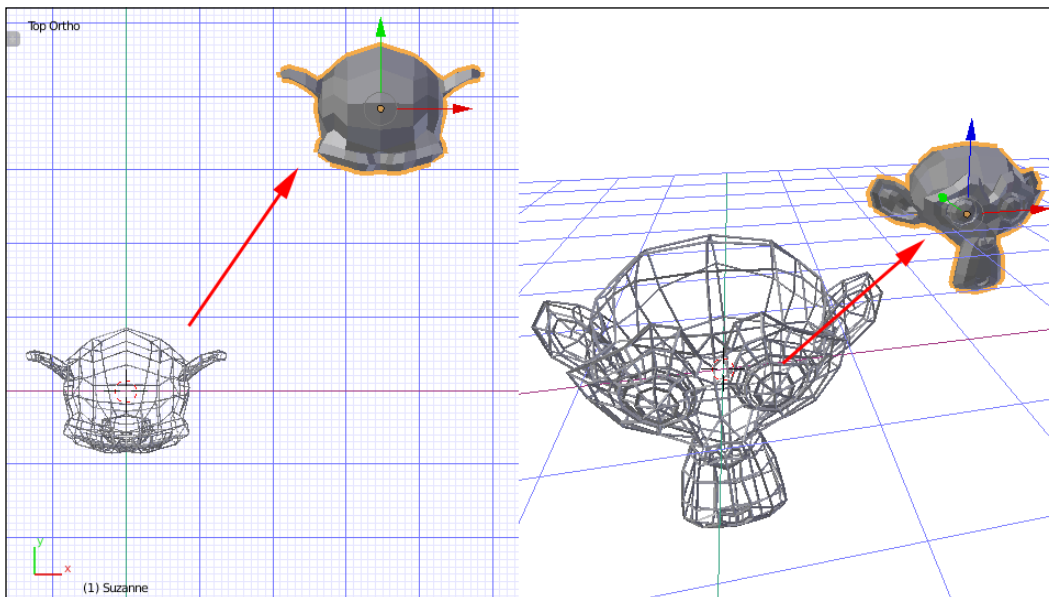

Adjust the view to see how exactly how the object moved. When moved while in the top view, the object stays on the grid plane. This is because from the top view, only forward, backward, and side-to-side motion is possible.

In the same way, moving objects while in the side views will only move them forward and back and up and down, and while in the front or back view, they will only move side to side and up and down.

Likewise, rotating depends on the view. When viewing from the top, rotation will be like, a top spinning around its middle. If viewed from the side when doing rotation, it will flip over its middle, and if viewed from the front, it will roll side to side around its middle.

Controlling the view is a quick and easy way of controlling movement and rotation, but always be sure to adjust the view to make sure things are happening the way you expect. However, to control scaling, as well as to control movement and rotation independent of the view, there is another way.

Axis locking

Blender has special commands for changing the behavior of operations. These commands are available while performing transformations.

The first thing to understand is about the three axes that we'll be locking along. 3D refers to the three dimensions, or unique directions, that things happen in. The dimensions are called by the letters *x*, *y*, and *z*. There is an illustration in the corner of the 3D View that shows which way is which, and is always pointing in the right direction:

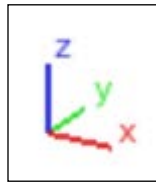

In Blender, and generally in 3D printing, *x* is side-to-side motion, *y* is back-and-forth motion, and *z* is up and down. In the previous screenshot, the *x* axis is red, *y* is green, and *z* is blue.

When performing a transformation, you can lock the transformation to the axis you want by starting the transformation as mentioned previously, and while moving the mouse or using the keyboard, doing the following:

- Pressing *X*, *Y*, or *Z* on your keyboard to lock the transformation to the desired axis
- Pressing *Ctrl + X*, *Ctrl + Y*, or *Ctrl + Z* to lock the transformation to all but the chosen axis

- Holding the middle mouse button and moving the mouse to choose an axis to lock the transformation to

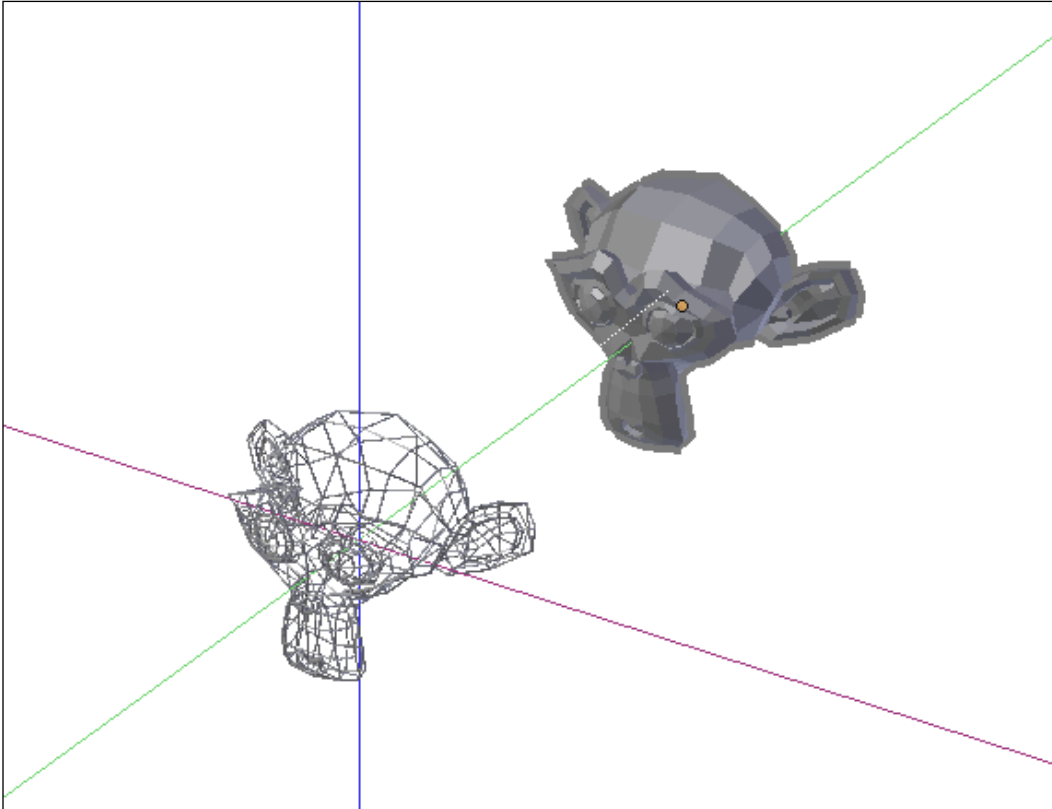

Try out axis locking with movement, rotation, and scaling, and adjust the view to see what effect it has. Notice that with axis locking, the scale function has some additional abilities that aren't possible just by controlling the view. It actually only scales in the chosen axis. This can be very powerful while adjusting the shape of objects.

Precise transformation

Finally, under the category of controlling transformations, during transformation operations, the transformation can be precisely controlled by typing in a number that will relate to the operation being performed or edited afterwards in the operation properties in the tool box, on the left side of the **3D View**. In other words, to move something exactly two units up, for example, follow these steps:

1. Select the object.
2. Start the movement transformation (*G*).
3. Type *Z* to lock the movement to the z axis.
4. Type *2* on the keyboard.
5. Press *Enter* or click the select mouse button to finish the operation.

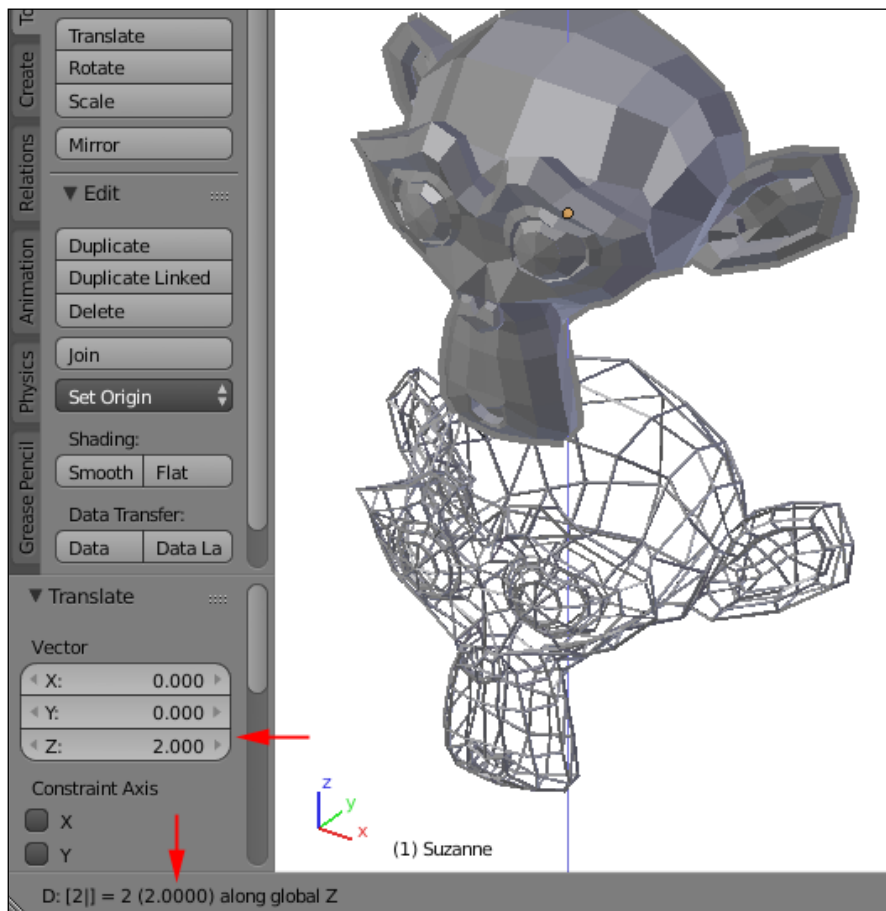

Typing commands has different effects for different commands, as follows:

- When moving, typed commands are used to state the number of units an object will move along the selected axis. For example, 2 along the z moves it two units up, and -2 along the z moves it two units down.
- When scaling, typed commands specify the scale factor. 1 means no change, 2 means twice as big, and 0.5 means half size.
- When rotating, typed commands specify clockwise degrees. For instance, 180 turns it around backwards.

Typed commands can include negative numbers and decimals and can be edited with the *Backspace* key. While performing a transformation, the menu for the **3D View** changes to a description of the transformation, including the typed units, which can be useful when editing your typed commands.

Origin manipulation

Objects in Blender have an origin. Origins are depicted as a dot and start out in the middle of the object. Individual object transformation commands take place relative to the object's origin. It's possible that the origin can be moved as a result of editing, which can cause unexpected results when rotating or scaling the object. The origin can also be moved on purpose to control the effect of modifiers.

The origin can be reset using the origin controls. The origin controls can be found by one of the following methods:

1. In the **3D View** menu, choose **Object | Transform** and find the origin controls.
2. In the **Tool Shelf**, find the **Set Origin** dropdown and choose the desired option.

3. On the keyboard, press *Ctrl + Shift + Alt + C*.

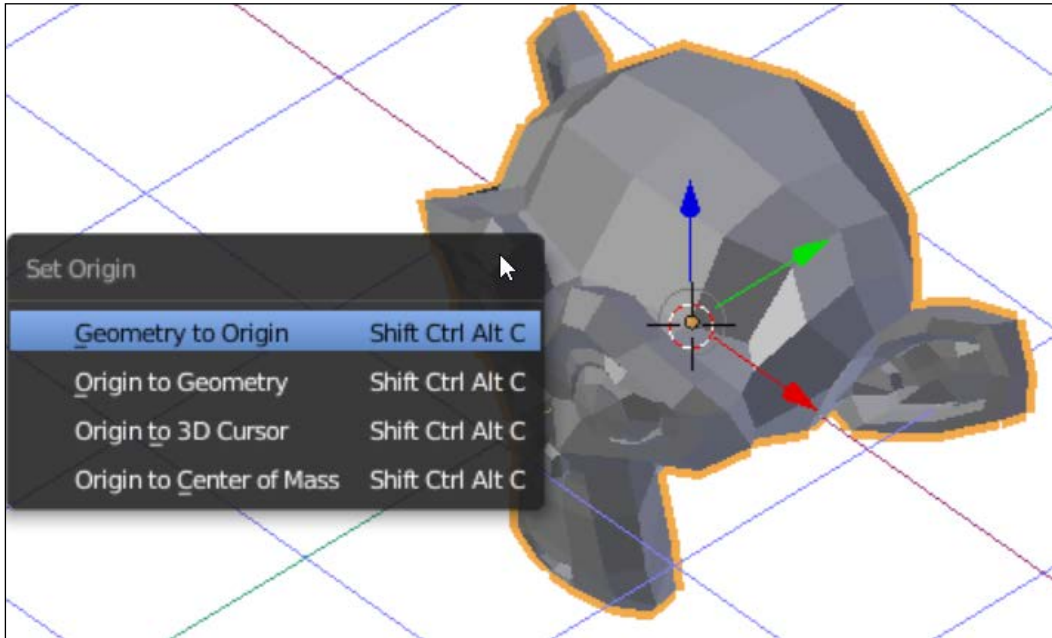

These are the commands to manipulate the origin:

- **Geometry to Origin:** Move the object so that its middle is now wherever the origin was located.
- **Origin to geometry:** Move the origin to the middle of the object. This is the most common option chosen.
- **Origin to 3D Cursor:** Relocate the origin to where the 3D cursor is.
- **Origin to Center of Mass:** Calculate the center of mass of the object and move the origin there.

Duplicating objects

Blender can duplicate existing objects. This is very useful and can speed up making things. To duplicate an object, follow these steps:

1. Select the object to be duplicated.
2. In the **3D** menu, choose **Object | Duplicate** or press *Shift + D*.
3. Move the mouse or use the arrow keys to place the duplicate (axis-constraining commands also work at this point).

4. Press *Enter* or the select mouse button.

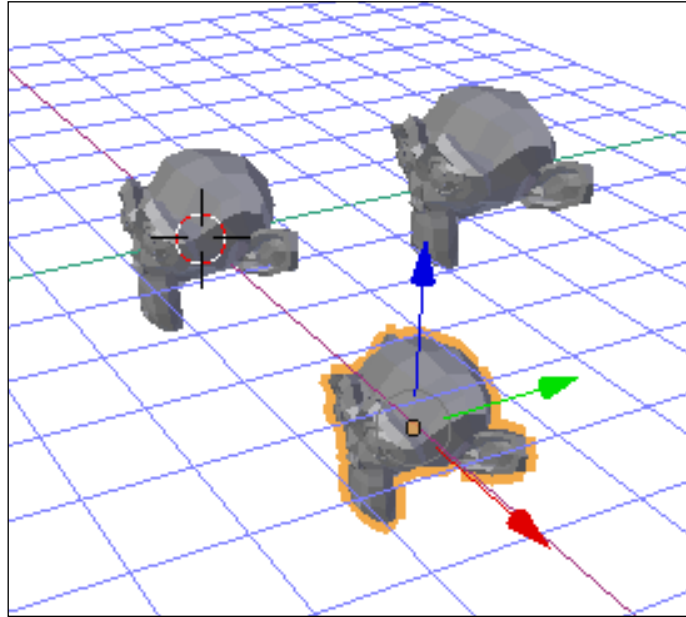

Object selection

Naturally, Blender is capable of selecting more than one object at a time. Blender has many tools to help when selecting objects. With multiple objects, the transformation commands work on all the selected objects at once. This is a powerful way of controlling transformations while keeping objects in relative positions to each other.



To practice selection, there need to be multiple objects to select. Create a scene, add an object, and then use the duplicate (*Shift + D*) command to create many objects from the one. Spread them around the scene so that they can be selected with the following tools.

Shift select

One way to select multiple objects at once is to hold down the *Shift* key while clicking on the desired objects one at a time. To deselect an object, it must first be made active. The active object is highlighted in a different color. Then it can be clicked again while holding the *Shift* key, and it will be removed from the selection.

Border select

Another way to easily select multiple objects in a scene is to use the border select command and draw a box around the objects you want to select. To border select, choose **Select | Border Select from the 3D View** menu or press **B** on your keyboard. Then, click and hold down the select mouse button, move the mouse pointer, and release the mouse button:

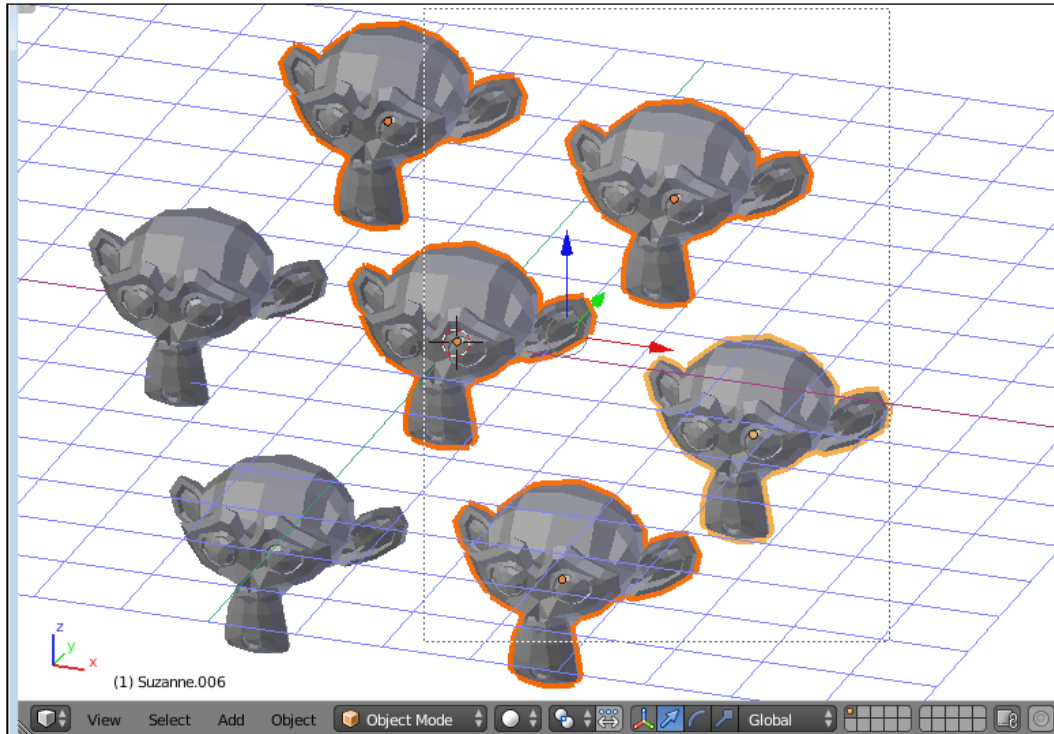

If even a small part of an object is included in the box, it will be added to the selection.

To deselect objects with border select, use the middle mouse button when drawing the box.

Circle select

Circle select is another powerful tool for selecting multiple objects. To circle select, choose **Select | Circle Select from the 3D View** menu or press **C** on the keyboard. A circle will appear around the mouse pointer. Use the scroll wheel or **+** and **-** on the Numpad to increase or decrease the size of the circle. Then, click or click and hold the select mouse button, and everything inside the circle will be selected. Use the middle mouse button to deselect:

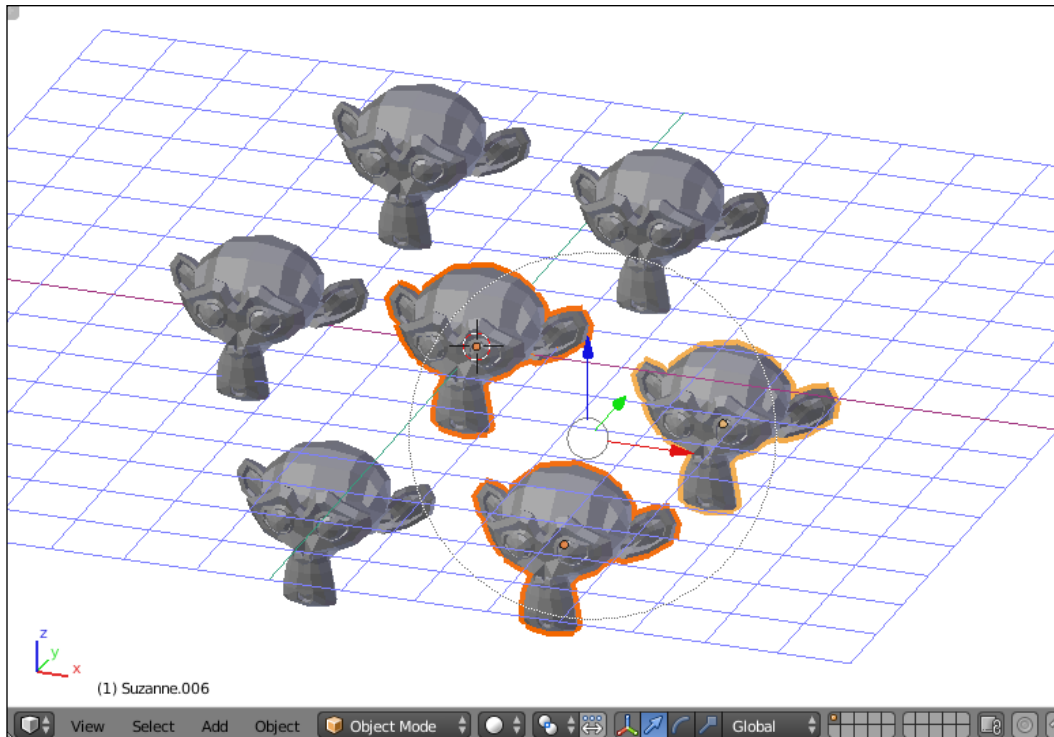

Circle select only adds or removes an object from the selection if its center or origin is inside the circle when selecting.

The Edit mode

In Blender, the **Edit** mode allows more access to the shape of a single object so that it can be manipulated in order to change its shape. To enter **Edit** mode, use this method:

1. Select an object.
2. In the **3D View** menu, locate the mode pop-up menu and select **Edit Mode** or press *Tab* on your keyboard.

In **Edit** mode, the **3D View** menu, **Tool Shelf**, and **Properties** all change, adding new functionality only available in **Edit** mode:

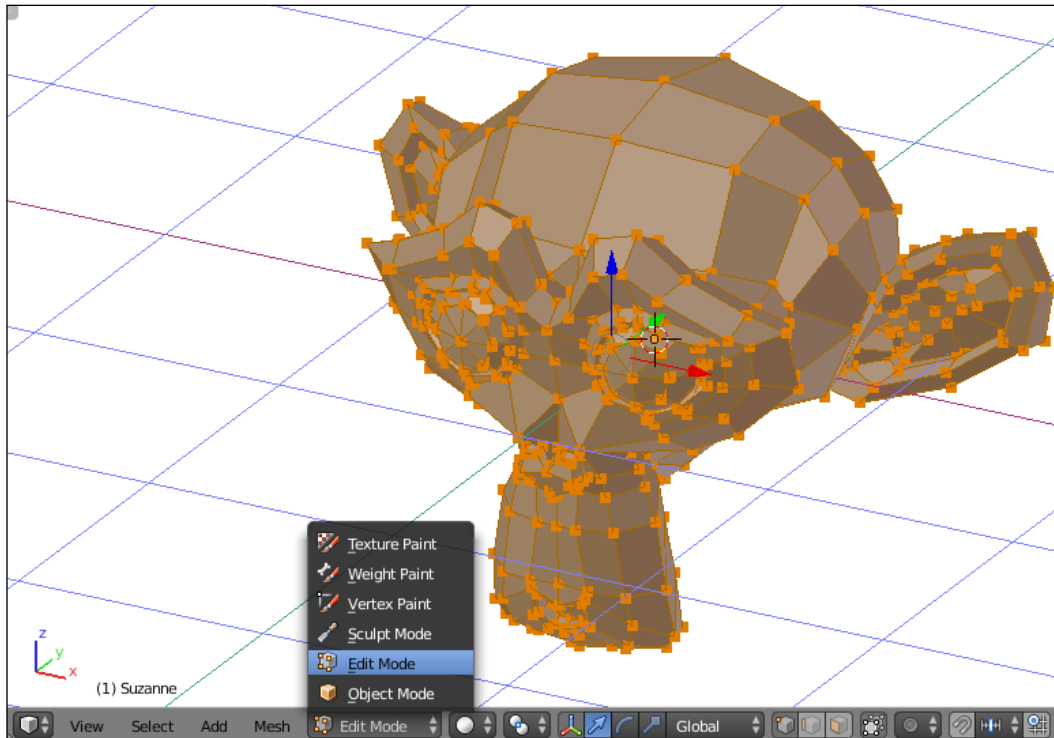

Parts of objects

In **Edit** mode, objects are broken down into three parts:

- **Vertices:** Points in three-dimensional space. Vertices don't have any shape by themselves
- **Lines:** Two points are connected with a straight line between them
- **Faces:** Three or more lines can be connected to make a face

There are many ways to think about vertices, lines, and faces. For instance, if making a kite, the vertices are the joints, the lines are the sticks, and the bits of paper are the faces. If the location of the vertices is moved, the shape of the kite will change. It's the same with a 3D object. Editing by vertices, lines, or faces will affect the rest.

The **Edit** mode is by default in vertex select mode, meaning any selection or transformation is applied to vertices, but it's easy to switch by locating the vertex, line, or face select buttons in the **3D View** menu or by pressing *Ctrl + Tab* and selecting the desired option from the menu that pops up:

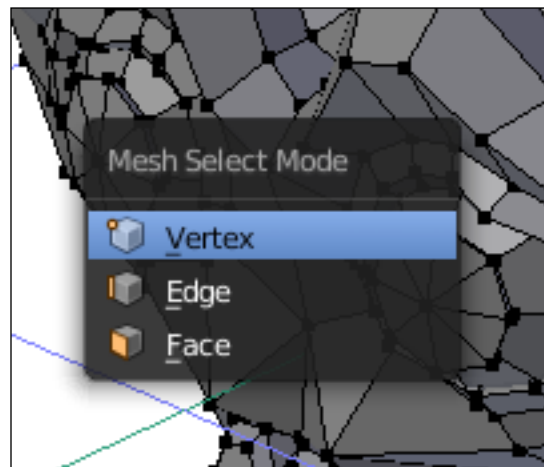

Try out **Select** mode. Select groups of vertices, edges, and faces, using circle and border select. Try moving, rotating, and scaling them and see how it effects the shape of the object. Try simple basic shapes such as cubes and circles. See how **Wireframe** mode affects selection. Notice how the other objects in the scene can't be accessed.

A lot of what happens in the projects will happen in **Edit** mode. But the individual projects will better teach you how to use it.

Incremental saving

It is always a good idea to save your work frequently. To save your work in Blender, choose **File | Save** from the info panel or press *Ctrl + S*. Then, navigate to a chosen folder or directory, give the file a name, and click on the **Save As Blender File** button or press the *Enter* key.

It is recommended that each Blender project gets its own folder and that all projects be saved in a location that will be easy to find later.

It is also a good idea, while learning especially, to give each version of the file you save a slightly different name. This way, there is a history of the work done and it's easy to go back in the case of a mistake that isn't discovered immediately. This is called incremental saving and is simple to do in Blender. Simply choose **File | Save As** or press *Ctrl + Shift + S* to get to the save menu. If the project has been saved previously, it should already have a name. Next to the filename, there are plus and minus buttons:

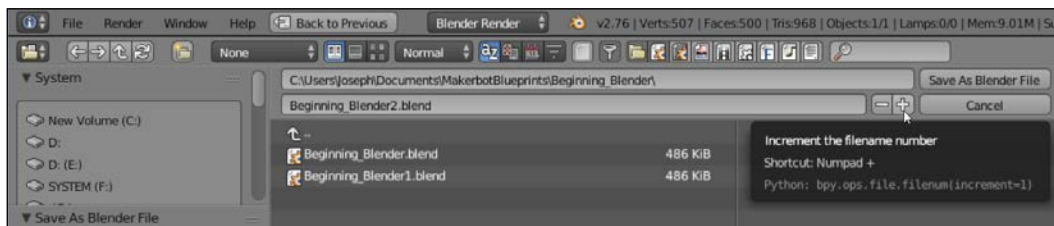

By clicking on those buttons, the filename will have a number attached to it, and that number will be increased every time the plus button is clicked. Then, click on **Save as Blender File** or press the *Enter* key to save the file with a new filename.

Blender to real life

By default, Blender units don't make any attempt to relate to real-life measurements. However, after exporting a mesh, the slicing software will interpret the Blender units as millimeters, generally. So, it is good to think of Blender units as millimeters. This means that default objects in Blender are 2 mm across when they're added, which is fairly small.

Remember that one blender unit will be 1 mm when the file is used to 3D print an object.

Exporting an STL

Before they can be used in a 3D printer, 3D models created in Blender have to be changed to a file that the 3D printer can use. Blender's default file format isn't readable by 3D printers and can sometimes contain additional information that the 3D printers don't need.

Most 3D printers use a file format called **STereoLithography (STL)**, which contains just the final shape of the object. To export a finished model to an STL for 3D printing, follow these steps:

1. Select the model or models to be exported.
2. From the **Info** panel, choose **File | Export | Stl (.stl)**.
3. Navigate to a chosen folder or directory.
4. Give the file a name.
5. Click on the **Export STL** button or press the *Enter* key:

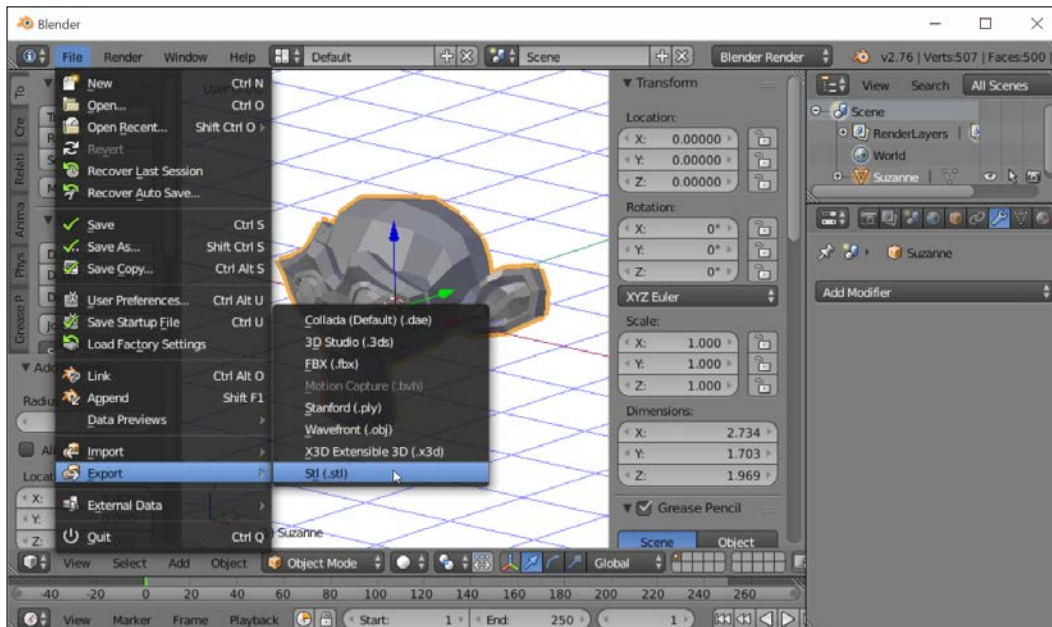

Now, the STL file will be available to send to a 3D printer or printer service.

If multiple objects are selected, the exported STL will have the objects in the same relative orientation to each other; therefore, it's important that they don't overlap and are printable as oriented. It's often preferable to save separate objects in separate files.

Summary

A recent poll of online social sites about 3D printing showed Blender was the most popular choice for creating models for 3D printing. The reason is obvious, taking into account Blender's vast functionality. However, it could just as well be that more people were talking about Blender because of its challenging learning curve.

Blender is capable of creating simple primitive shapes, viewing them from any angle, transforming them with precision, and manipulating their individual vertices, edges, and faces in the powerful editing mode. The model can then be exported to a file, ready to be 3D printed.

Blender has many functions not even covered in this chapter, such as sculpting, skeletal manipulation, and how to use individual modifiers to achieve specific results. As these functions become important for individual projects, they will be covered.

Hopefully, this chapter served to introduce how powerful and comprehensive Blender is. However, Blender's comprehensive nature comes at the cost of being complex, which can be overwhelming. But don't worry. Keep this chapter at hand to act as a reference and a crutch in future projects until Blender's functions become second nature. It usually only takes one project before Blender becomes second nature. Once Blender is familiar, no other 3D modelling software will be necessary.

3

Sculpting the Face of the Sun

Sometimes, 3D printing needs to be precise and practical. And sometimes, it just needs to be fun, like the wood-cut puzzles your grandpa may have made in his garage. We'll be making similar puzzles but with a whole new dimension in order to take advantage of the power of 3D printing.

In addition to the basic 3D editing tools you've already learned about, Blender also includes some robust sculpting tools that enable editing objects with actions similar to drawing or building up clay. Because of its nature, sculpting facilitates a very organic modeling process.

There are a lot of sculpting tools available, and each one has a special use. The project in this book will use the most popular and useful of them to sculpt a simple model. This model will then be combined with basic editing outside of sculpt mode to create a 3D puzzle.

Creating the base object

Since the editing tools can only work on existing objects, the first thing to do is create a new object:

1. Start Blender and select all objects (A) and delete them (X).

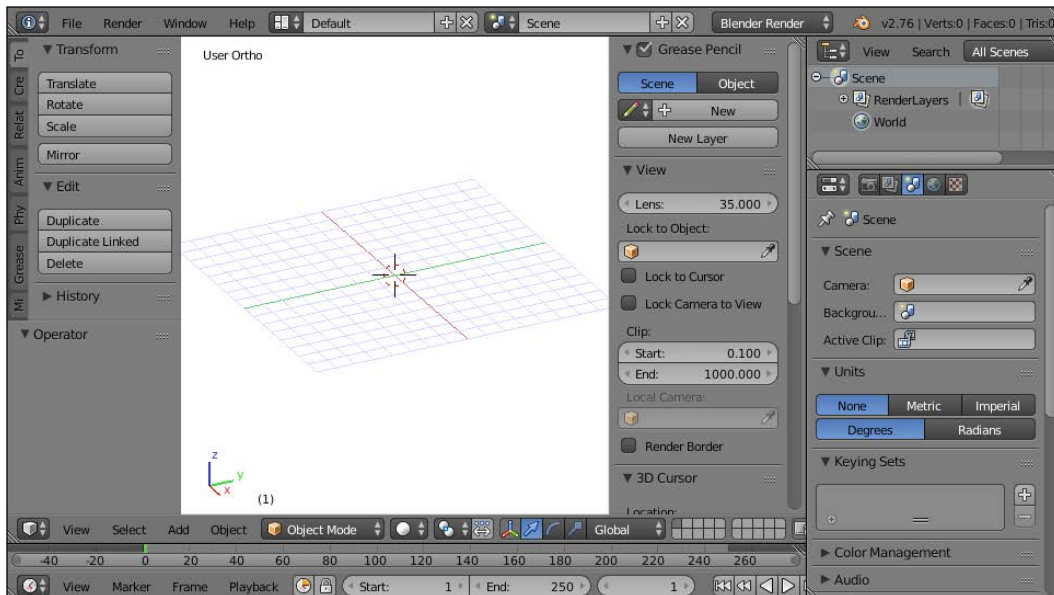

2. Then, add an icosphere (*Shift + A*) through **Mesh | IcoSphere**.

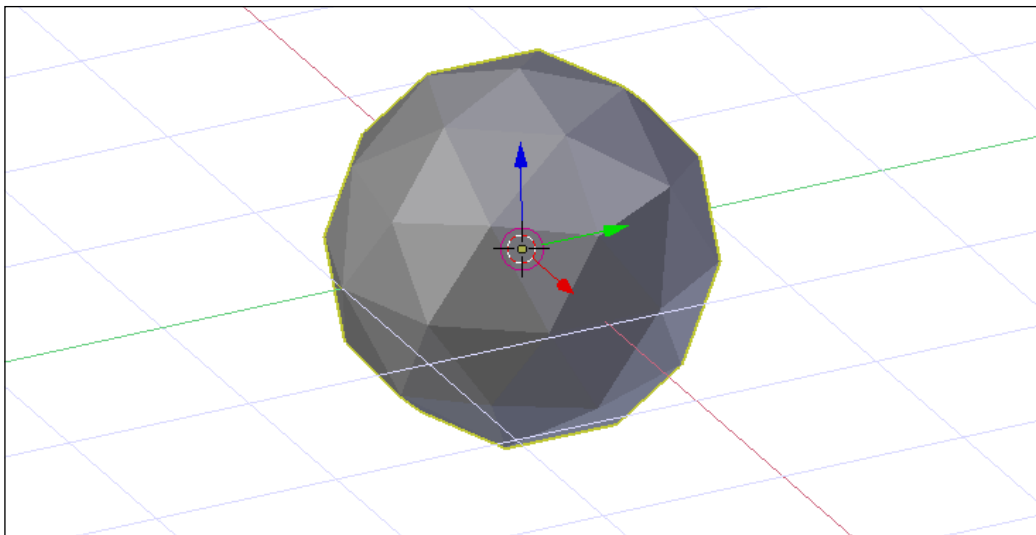

Icospheres differ from normal spheres in that they don't bunch up at the poles. This will work out better for sculpting. But if viewed from the top (Numpad 7), the icosphere is not symmetrical from left to right. To fix this, follow these steps:

1. Rotate (*R*) the icosphere 90 degrees along the Y axis (*Y*).

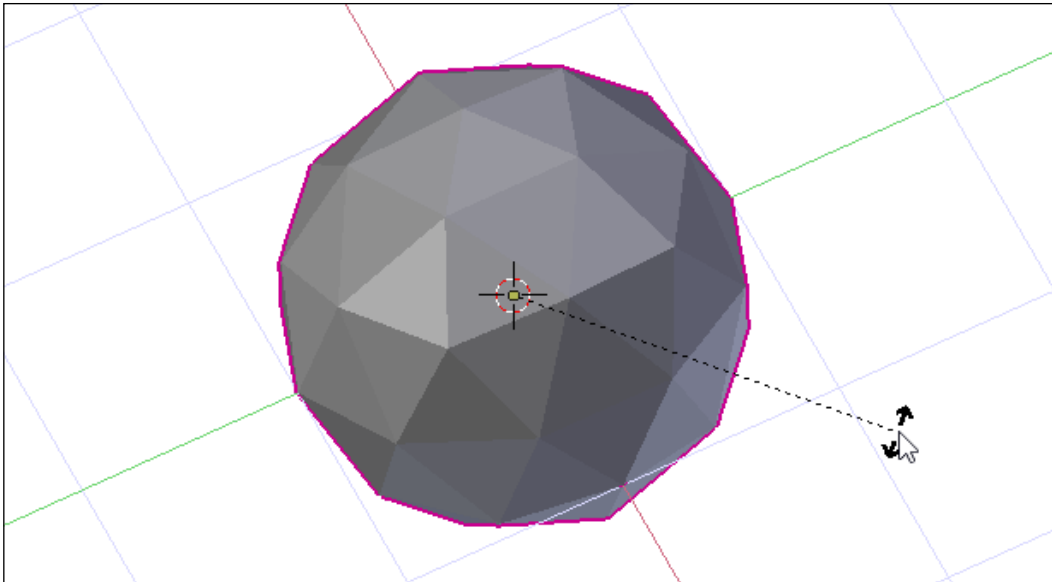

2. To make the icosphere into a disk, scale it (*S*), constraining to the X and Y axes (*Shift + Z*), to about a factor of 5.

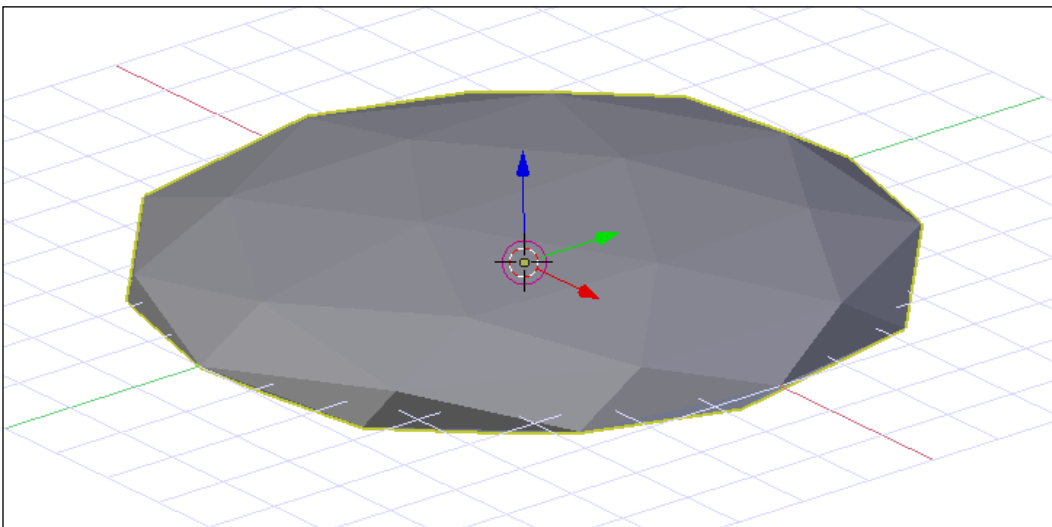

3. When the disk is the right shape, apply (*Ctrl + A*) **Rotation & Scale**.

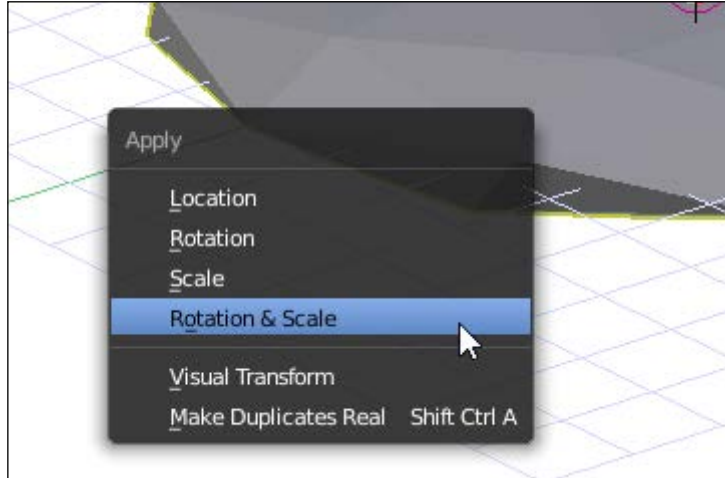

Applying rotation and scale doesn't have any visible effect on the model, but it will affect other things, particularly those related to the sculpt tools. Before applying rotation and scale, the object you see was actually another object modified with rotation and scale and could be undone. After applying it, the object you see is what the object actually is. It bakes in the changes. This is important because some actions, such as sculpting and some modifiers, are actually applied to the base object.

Setting up sculpt

When entering sculpt mode for the first time, it's worth knowing the settings available to you and becoming acquainted with a few commonly changed defaults:

1. In the menu bar at the bottom of the **3D View** panel, click on the **Object Mode** dropdown and select **Sculpt Mode**.

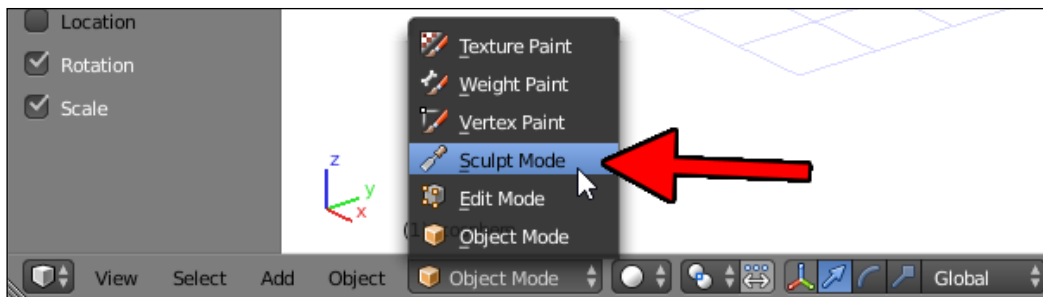

- Once you enter **Sculpt Mode**, the tool shelf to the left of the **3D View** panel will change. In the **Tools** tab, there are a number of sections. The most common settings are in the **Brush**, **Symmetry/Lock**, and **Dyntopo** sections. Like most things in Blender, these can be customized and rearranged, so it might be desirable to change the order of these sections to move them to the top.

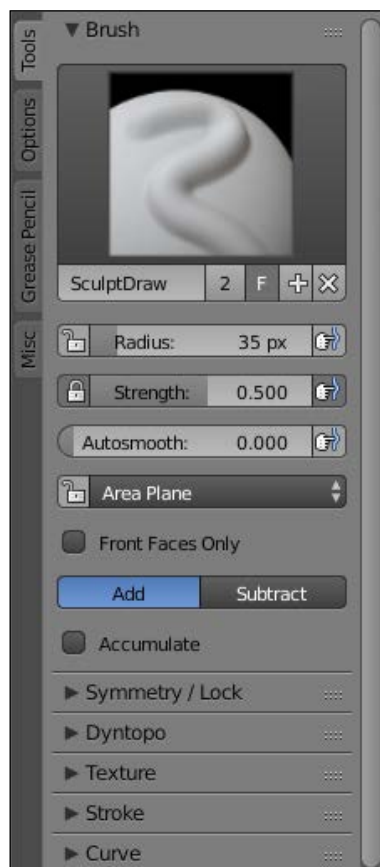

The **Dyntopo**, or **dynamic topology**, section has settings related to a relatively new feature for sculpting in Blender. Dynamic topology will increase or decrease the complexity of the model in whatever local area needs it in order to make the details we want to add. In other words, if we want a lot of detail on the top of the model where we'll be doing all our work, but not the bottom, which is mostly going to be ignored, we don't have to worry about making the whole model more or less complex. Dynamic topology will handle all that for us. But it needs to be turned on.

3. Open the **Dyntopo** section and click on the **Enable Dyntopo** button.

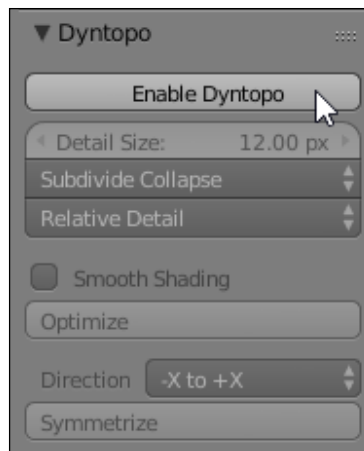

4. Change the **Detail Size** setting to 5.00 px.



The **Detail Size** value is how big the polygons will be made when sculpting. Notice that this setting is in px or pixels. This is a setting based on the view, not any actual measurements. If the view is zoomed in closer to a model, there will more detail added. When you zoom out, the detail may be reduced, eliminating some smaller details.



If you find that your computer isn't able to handle as much detail as is being added to the models, you can adjust the **Detail Size** setting to a bigger number. If you decide you want more detail, you can set the **Detail Size** setting to a smaller number.

5. In the **Symmetry/Lock** setting, make sure the button marked **X** under **Mirror** is highlighted.

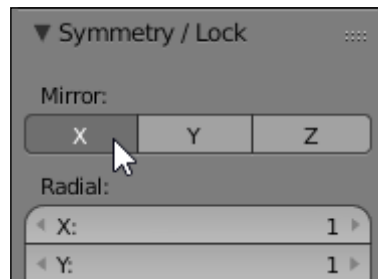

We're now ready to start sculpting our disk to make it a sunny face.

Drawing the face

In this section, we will make the face for our puzzle. Under the **Brush** tool, there is a whole palette of tools to use:

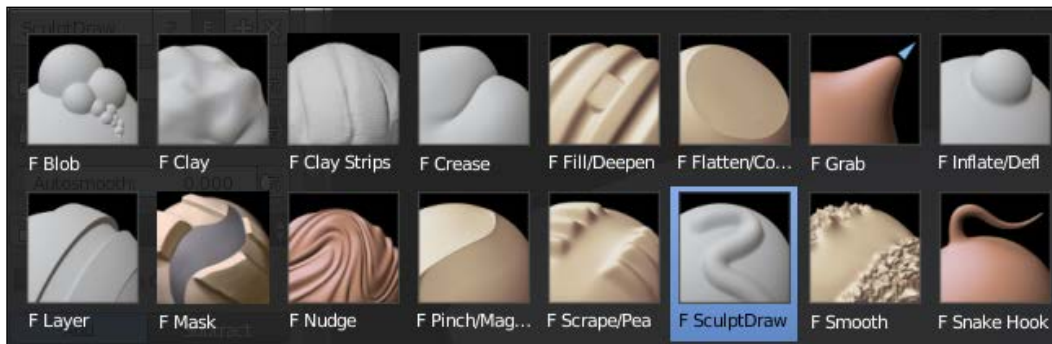

The default brush, **F SculptDraw**, is the most common and is already selected, so we'll start with it. Switch to the **Top** view (Numpad 7) and follow these steps:

1. From the middle, nearer to the bottom, click and drag in a curve to make a smile:

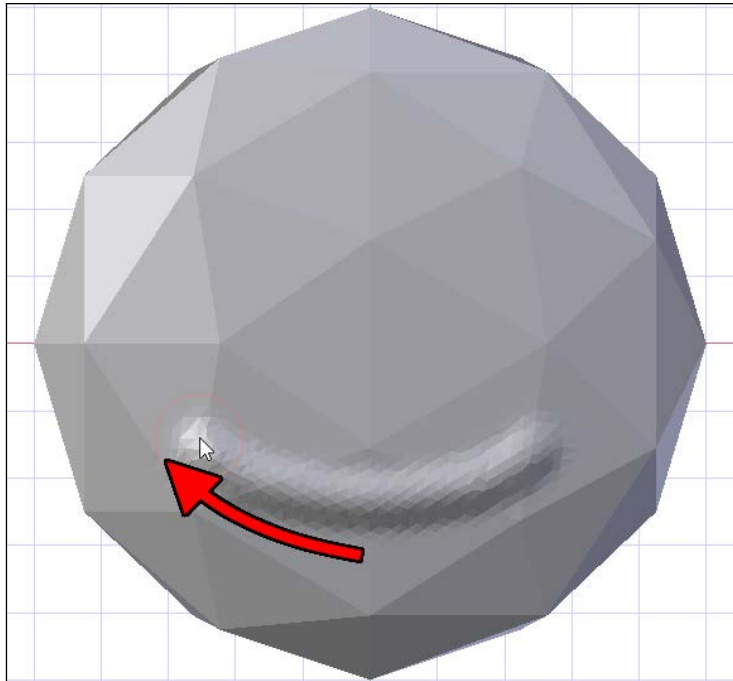

2. Repeat the action a little lower down to finish the lips:

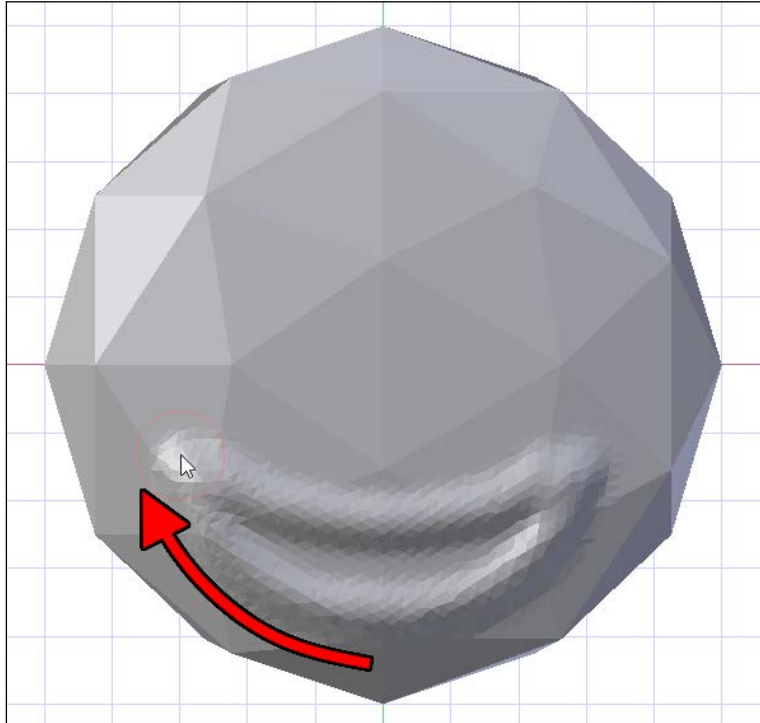

Remember, you can undo (*Ctrl + Z*) until the lips look the way you want them to.



Because of the symmetry setting, anything done on the left is repeated on the right, reducing work and making it easy for you to make a pleasing shape.

Because of dynamic topology, the rough polygons of the original shape are smoothed out so that all the details of the drawn shapes show through. This effect is easier to see if the view is switched to wireframe mode (*Z*).

Dynamic topology will continue to add detail where we need it as we sculpt:

1. In the **Tool Box**, increase the **Radius** setting under the **SculptDraw** tool to about 70 px:



2. From the outside edge, draw a downward curve towards the middle and go back along the same curve to the place the motion started for the cheek.

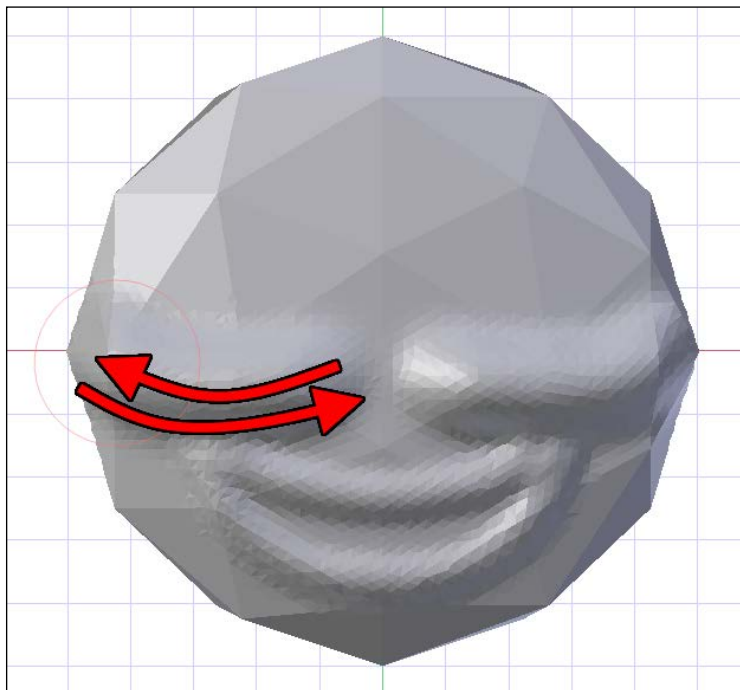

By repeating the motion back and forth, you can make the line taller than the lines for the lips if viewed from a different angle.

3. From the outside edge again, a little higher, draw an upward curve toward the middle for the eyebrows.

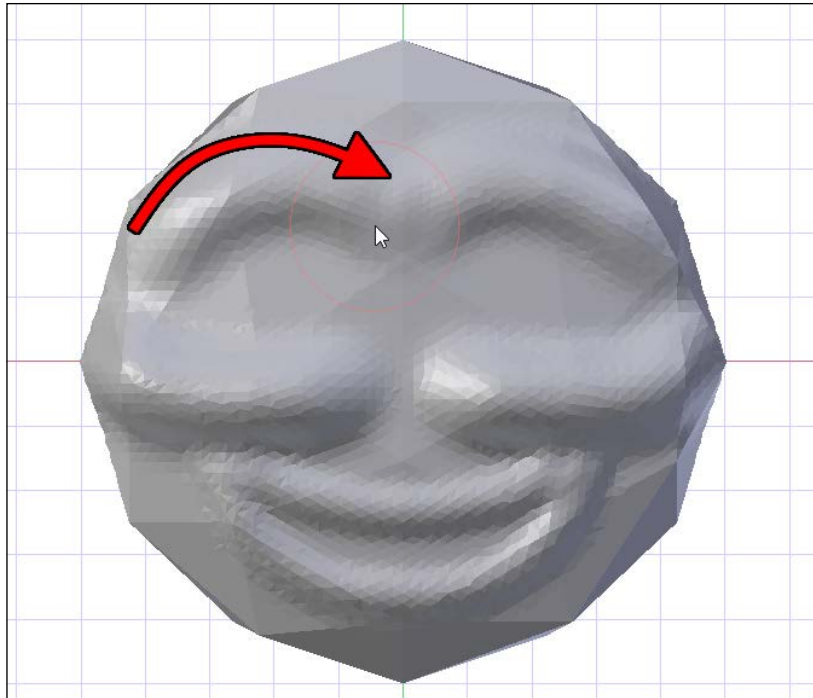

4. Now, set the **Radius** value to about 20 px. Click on the **Subtract** button to switch the drawing mode to **Subtract**:



5. Draw a little oval for the eye hole.

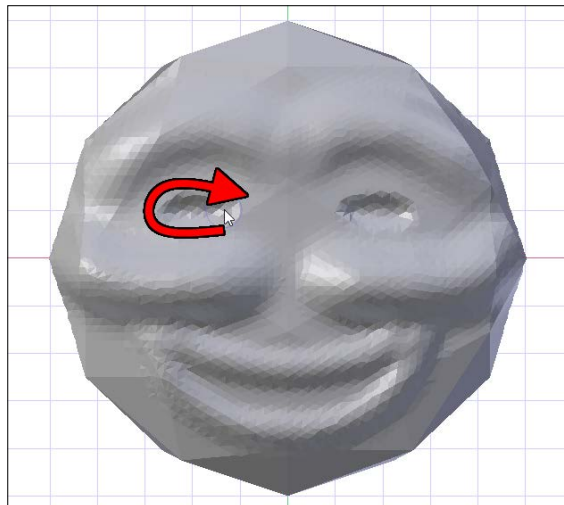

Smoothing the edges

At this point, the rough shape of the face is starting to develop, but now we need to smooth some things out. For this, we have the smoothening tool. Follow these steps:

1. Click on the **Brush** tool icon to pull up the sculpt tools.
2. Now, click on the **F Smooth** tool icon.

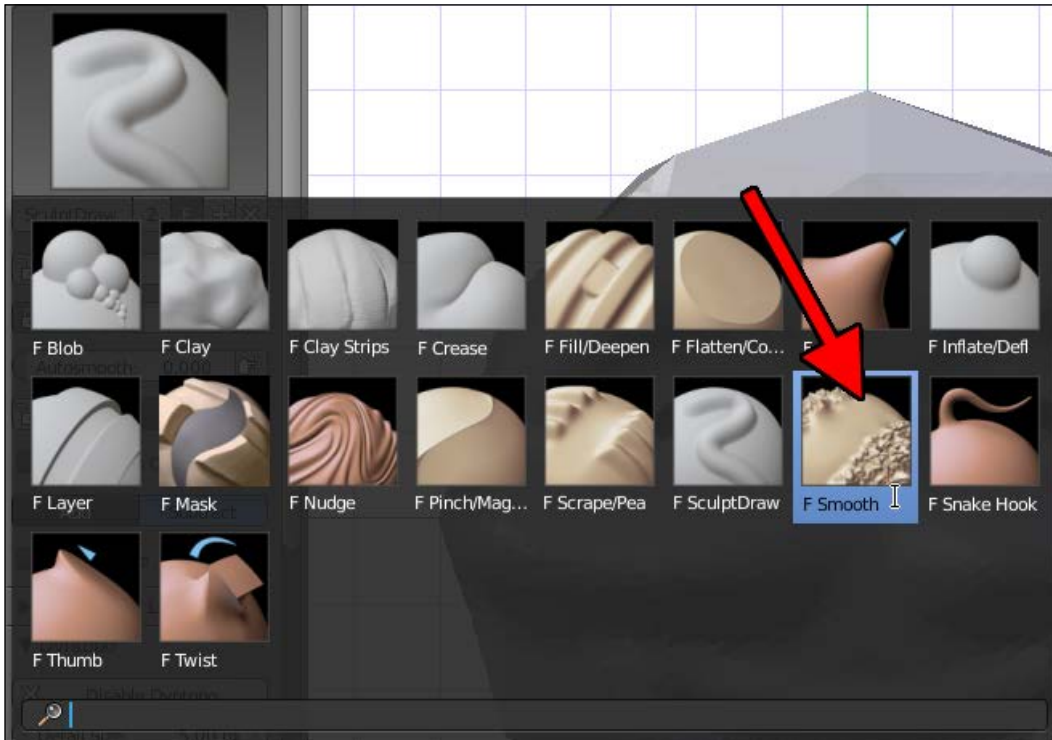

3. Draw back and forth along the curve above the lip to smooth out the upper lip.



4. Draw back and forth along the curve under the lip to smooth out the chin.



As with most things in Blender, it pays to know the keyboard shortcuts for this process. With sculpting, the easiest one is this interactive way to change the radius:

1. Hover the mouse pointer over the model and press *F* on the keyboard.
2. Move the mouse until the circle and brush shown are a little bigger than the space between the eye and the middle of the cheek.

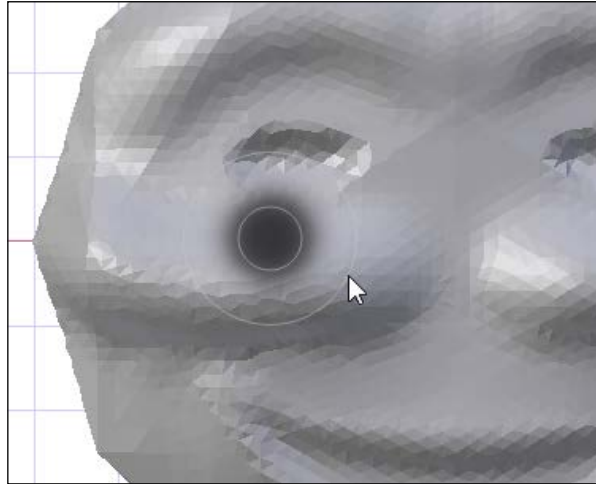

3. Click to finish the action.
4. Draw back and forth along the top of the cheeks to smooth them.

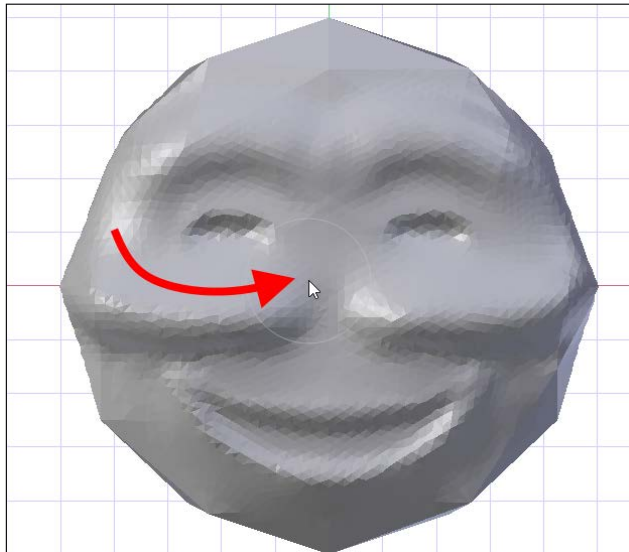

Adding the nose and eyes

To add the details of the nose and eyes, we'll use the **Inflate** tool. We'll also explore a few more keyboard shortcuts to simplify the process. The steps are as follows:

1. On the keyboard, type *I* to switch to the **Inflate** tool.



2. Use the *F* key to size the brush for drawing the nose.
3. Size the brush and click to complete the action:





Strength is another setting that can effect sculpting tools. You may have noticed it under the **Radius** setting. Setting **Strength** closer to 1 makes the effect of the tool stronger, while setting it closer to 0 makes it weaker, with 0.5 being a happy medium setting between them. For drawing the nose, a dramatic change by setting the **Strength** to 1 will save time and effort and, fortunately, there is a keyboard shortcut for doing that.

4. Press *Shift + F* on the keyboard to change the **Strength** setting of the tool.
5. Move the mouse pointer toward the middle of the **Radial** tool to increase the strength to 1.00.

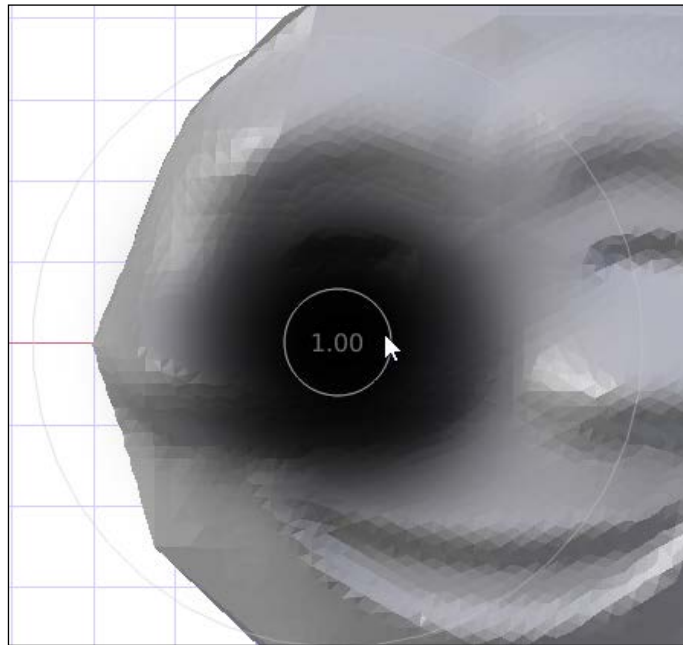

6. Click to set the strength.

7. Draw little circles around the nose area to build up the nose.

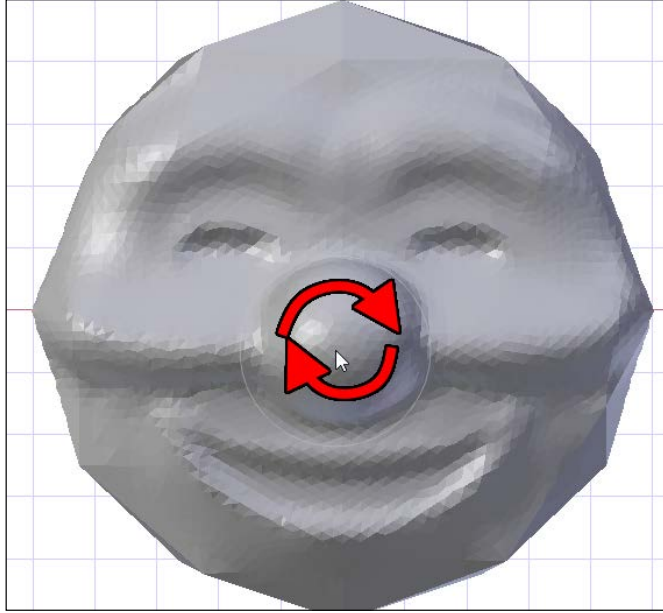

8. Hold down *Shift* while drawing in a line from the nose to where the eyebrows meet to quickly smooth out the bridge of the nose.

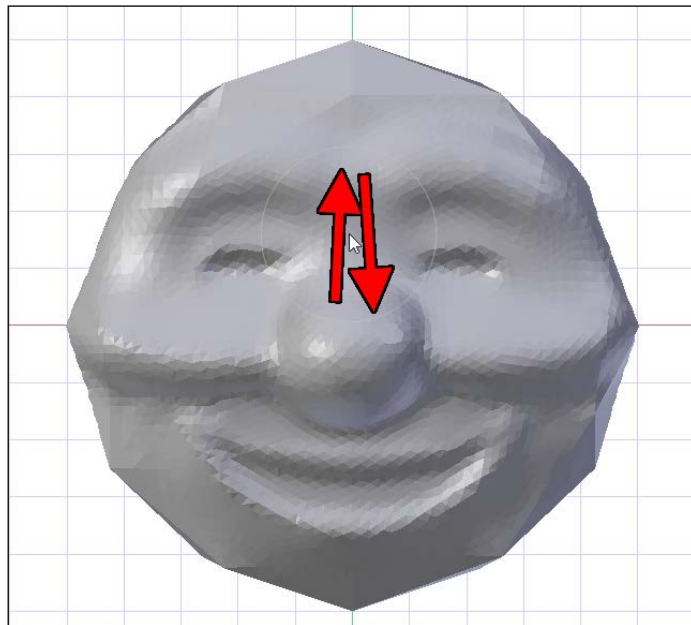

9. Adjust the view to be looking up at the nose from below.
10. Adjust the **Brush** size (*F*) to be about the size of a nostril.

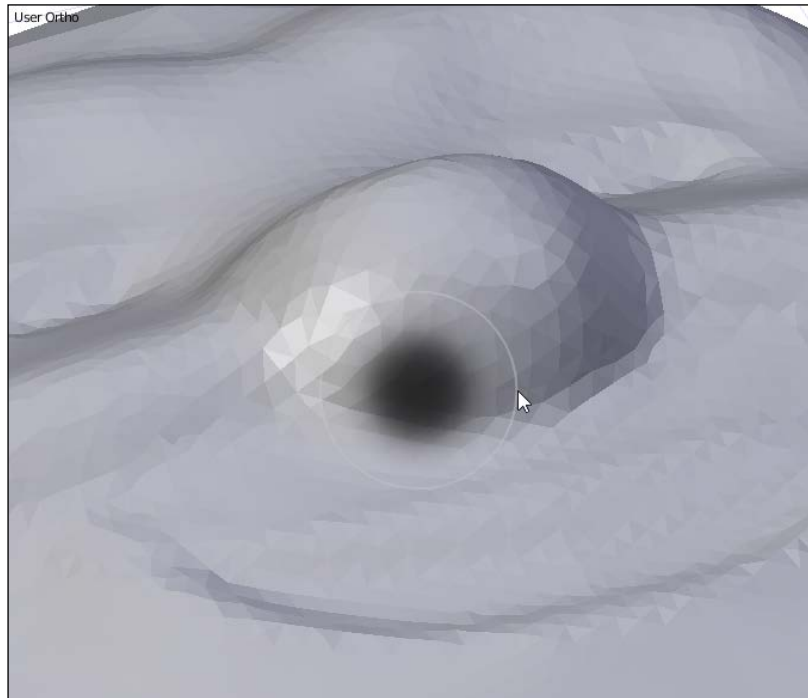

[ Holding down *Ctrl* while using a sculpting tool toggles the effect, switching add to subtract or inflate to deflate.]

11. Hold down *Ctrl* while drawing in little circles to deflate the nose holes into the nose.

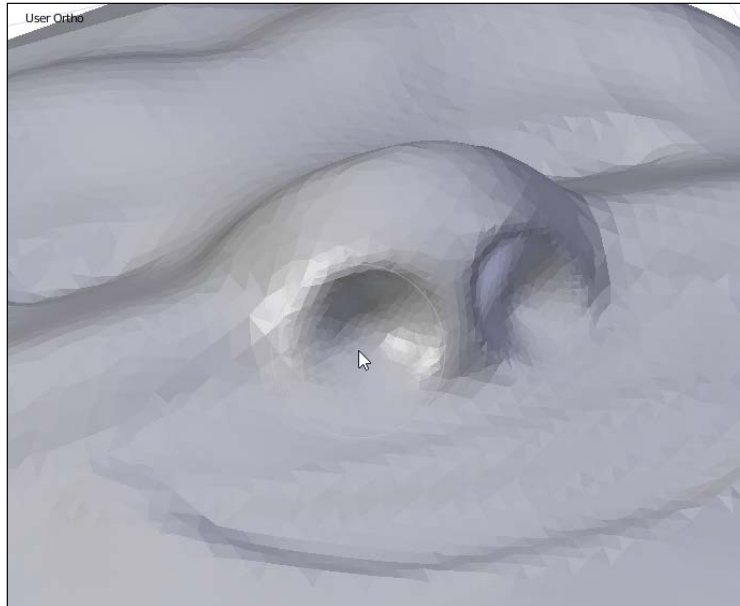

12. View from the top (Numpad 7) and zoom in the view to one of the eye holes.
13. Resize the **Brush** (*F*) to be a little smaller than the eye hole.

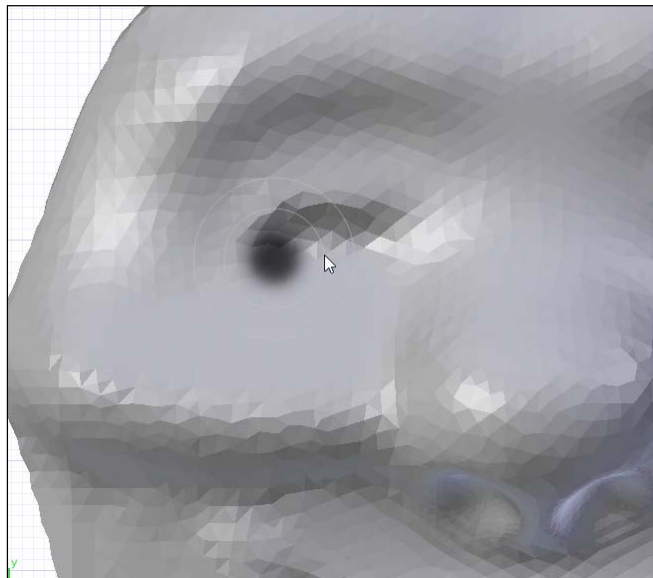

14. Draw little circles in the eye hole to build up an eye.

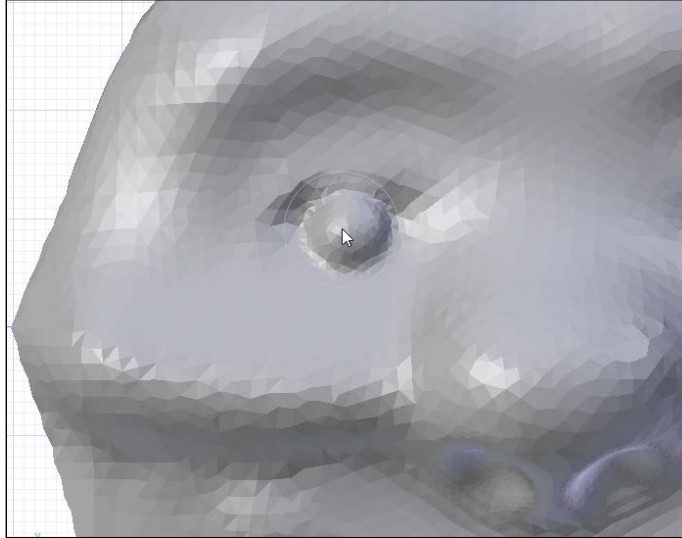

Pulling out the rays

We'll add more details to the face in a minute. First, let's finish out the main shape of the sun by pulling out the rays of the sun. The goal here is to make something curvy and artistic to look at, so for these parts, symmetry needs to be turned off first. Follow these steps:

1. On the left-hand side of the **3D View**, navigate to the the **Symmetry/Lock** part of the **Tools** tab in the **Tool Shelf** and click on the **X** button under **Mirror** to toggle X-axis symmetry off.

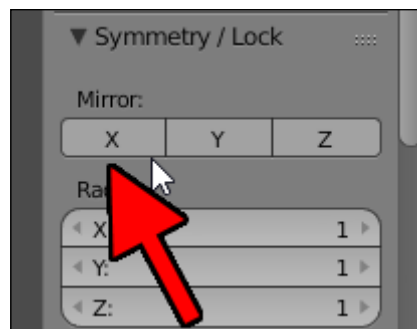

2. Switch to the **Snake Hook** brush (*K*).

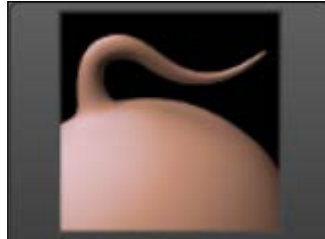

3. Adjust the view and change the **Radius** (*F*) so that the brush is about big enough to cover about an eighth of the edge of the face.

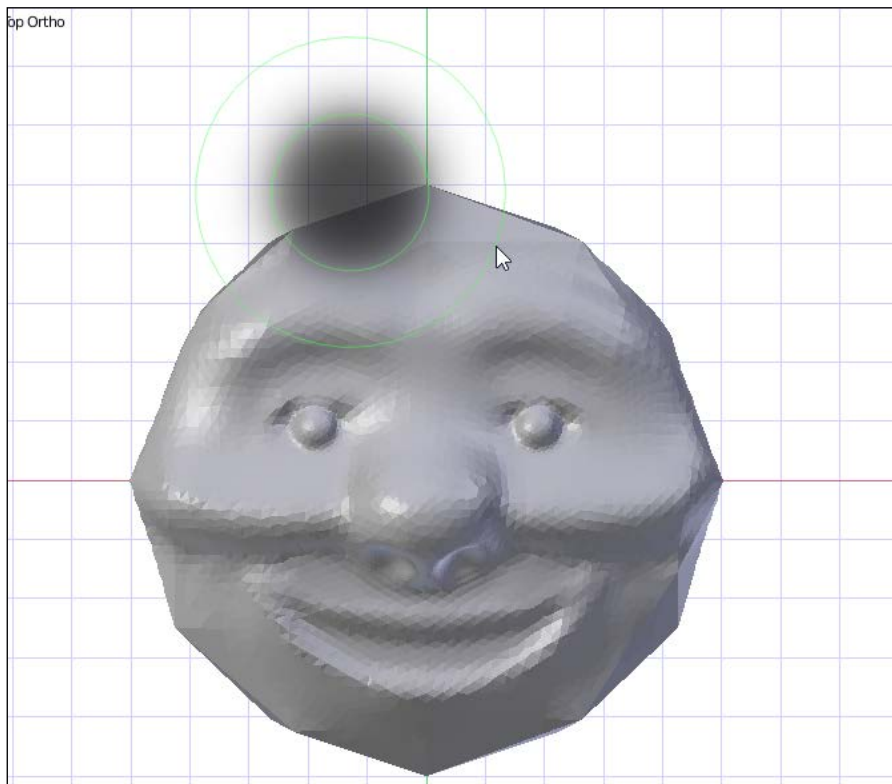

4. Adjust the strength of the **Brush** (*Shift + F*) to between 0.75 and 0.9.

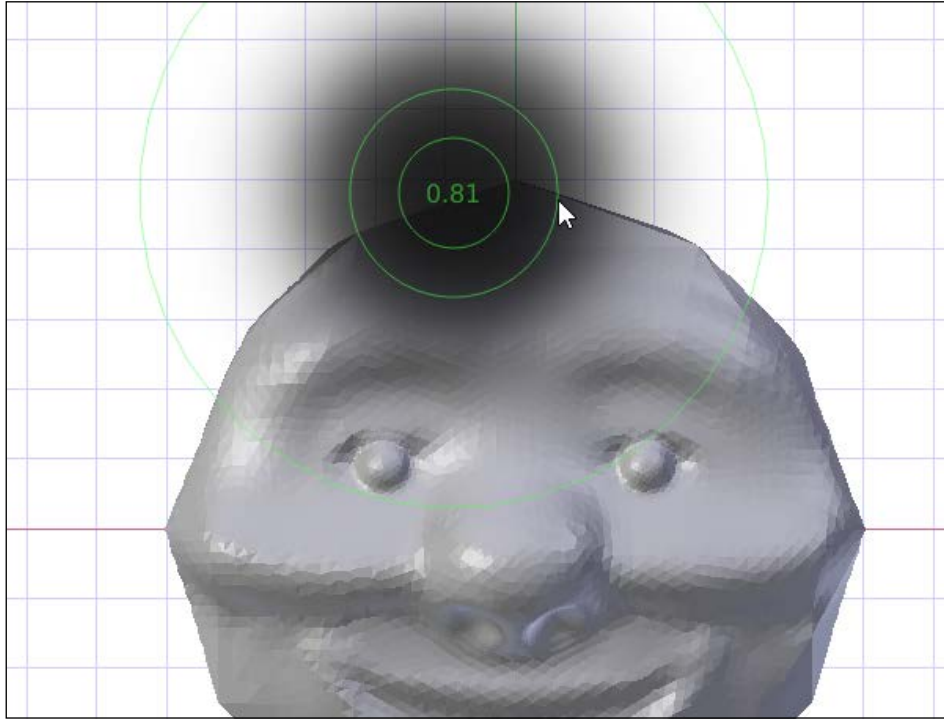

5. From the top of the head, being sure the center of the brush catches at least a little bit of the edge of the head, start drawing while moving the mouse in a curve away from the body.

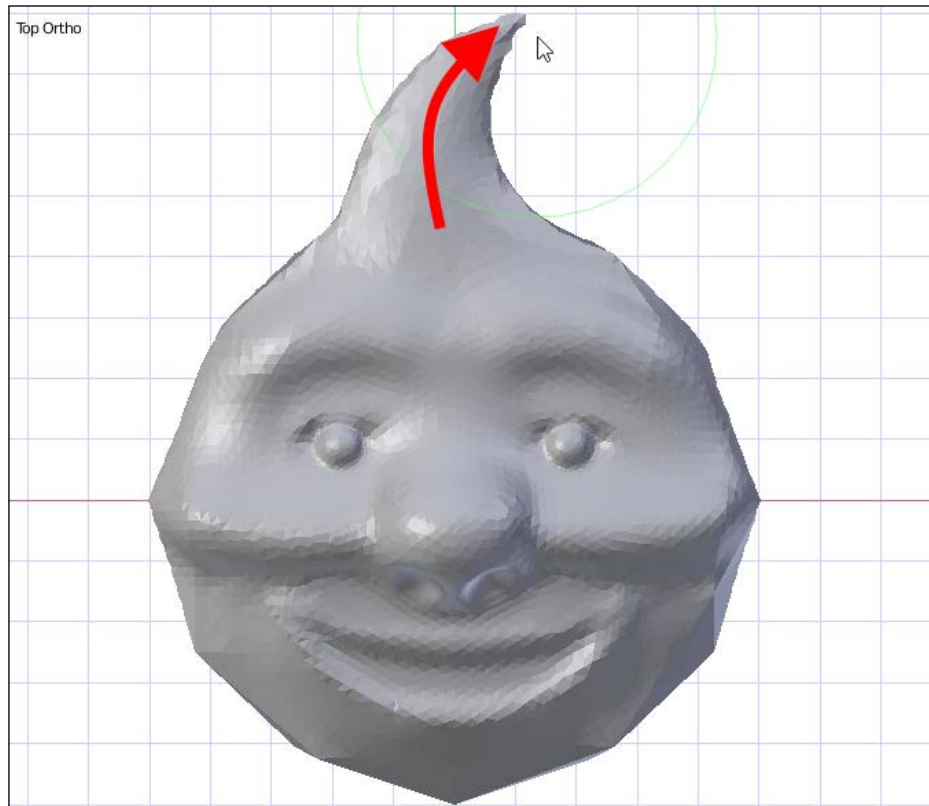

If the rays are being pulled out too far, undo the action, adjust the strength, and try again. If the brush is grabbing too much of the face, undo the action, adjust the radius, and try again.

6. Continue around the edge of the face, pulling out rays with the **Snake Hook** tool.

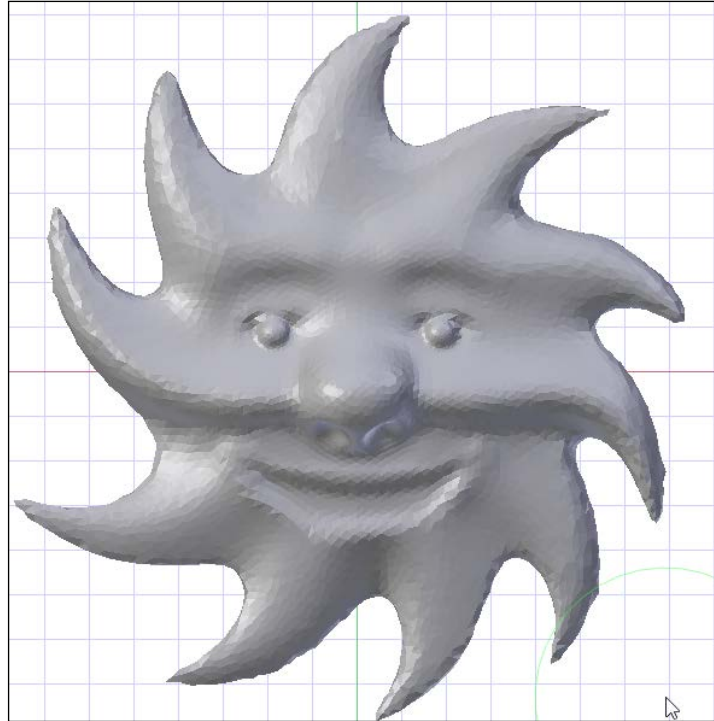

The **Snake Hook** tool is a useful tool because it quickly creates new areas that can be further sculpted. It can be used to make arms, tentacles, horns, or other shapes. Usually, it's preferable to generate a basic shape that is approximately shaped like the object to sculpt, but with **Snake Hook**, this doesn't necessarily have to be the case.

Sculpting is a more organic process than other modeling, so as you become comfortable with the tools, be sure to experiment with them and make the design your own.

Sharpening the details

At this point, the general shape of the face is set, but there can be more detail added. Keep in mind that with 3D printing, there is such a thing as too much detail, since some of it won't come through. Then again, details tend to be the most impressive part, so spending some time sharpening some edges may be of benefit. Here's how:

1. In the **Tool Shelf**, under **Symmetry/Lock**, click on the **X** button under **Mirror** so that it is highlighted in order to toggle mirroring back on.



2. Switch to the **Crease** tool (*Shift + C*).



3. Make sure the **Add** button in the **Tool Shelf** is highlighted. If not, click on it so it is highlighted.



4. Adjust the view and change the **Radius (F)** until the brush is big enough to cover the bridge of the cheek.



5. Draw a line following the bridge of the cheek to sharpen it a bit.



6. Draw in a line around the eyebrows and down the bridge of the nose.



7. While holding down *Ctrl*, draw a line following the curve of the mouth.

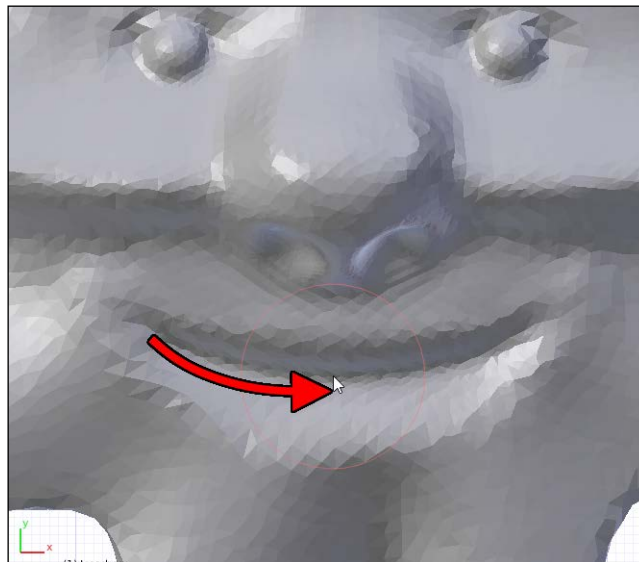

8. Adjust the view to zoom in on one eye.
9. While holding down *Ctrl*, deepen the crease around the eyes and maybe add some smile lines.

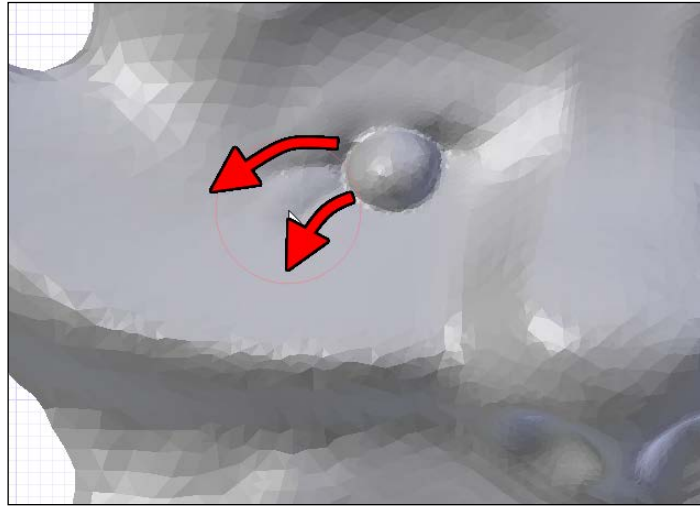

The **Crease** tool is great for adding small details such as lines or ridges to the model and can really give your design some style. But use caution – additive creases can create undesired ridges if overused. Be sure to adjust your view to make sure that isn't happening. If it does, remember that you can undo or smooth quickly without switching brushes by holding down *Shift* while drawing at any time as well. If elements aren't where you want them, the **Grab** brush (*G*) will allow you to reposition things to a certain degree.

10. Continue to adjust the look of the model until you're satisfied with the look.

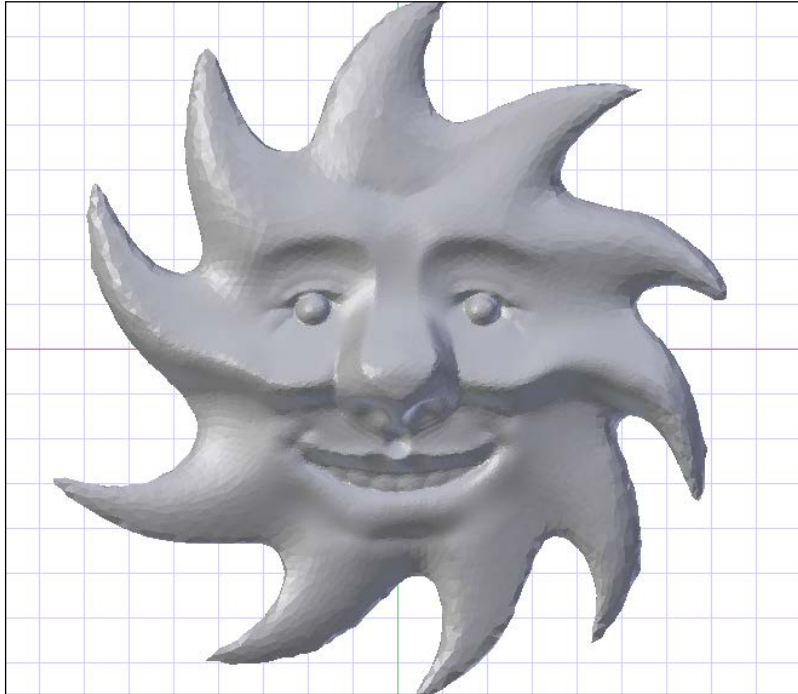

For the next steps, we'll be using the **Object Mode** tools, so after sculpting is done, switch back to **Object Mode** and click on the **Sculpt Mode** dropdown in the menu of the 3D View and select **Object Mode**:

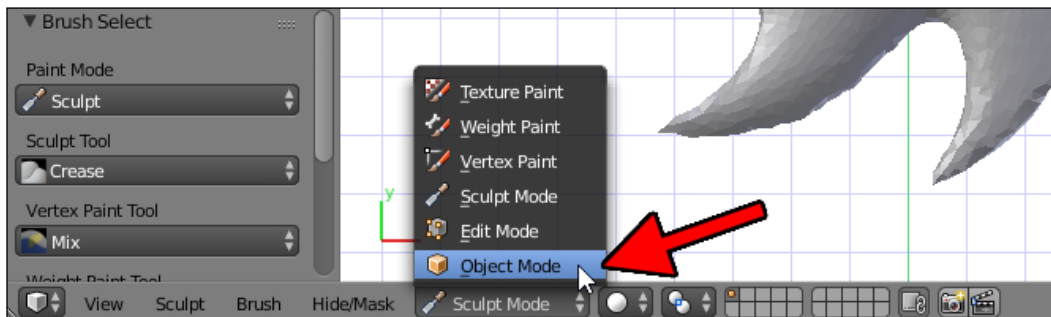



Here is a handy guide for easy reference to some of the keyboard shortcuts used in sculpt mode. For a complete set of shortcuts, be sure to check the Blender manual online.

- *F*: Change brush size
- *Shift + F*: Change brush strength
- *Shift* while drawing: Quick smooth
- *Ctrl* while drawing: Toggle brush direction.
- *X*: The **SculptDraw** brush
- *I*: The **Inflate** brush
- *Shift + C*: The **Crease** brush
- *G*: The **Grab** brush
- *K*: The **Snake Hook** brush

Summary

In this chapter, we used the sculpting tools in Blender to transform a basic shape into a complicated design. Dynamic topology managed the issues of resolution, automatically adding geometry where it was needed to create the effect we wanted. With tools such as **SculptDraw**, **Smooth**, and **Inflate**, the model quickly took shape. Hotkeys sped up the process. The **Crease** brush added some style and if it was required, the **Grab** brush gave us the power to adjust the placement of things, all with movements as natural as drawing.

In the next chapter, we'll take the model created here, combined with some more traditional modeling, and divide this model into a puzzle.

4

Cutting a 3D Jigsaw Puzzle

The sculpting was done in the previous chapter; it's now time to cut the model into pieces suitable for 3D printing. This is accomplished with Blender's traditional object-editing tools, as opposed to the sculpting tools used in the last chapter. Blender's combination of organic and more rigid object modeling is one of the things that makes it so powerful and versatile. In this chapter, we'll prepare the model, create the puzzle space, and apply that to the model to create the individual pieces:

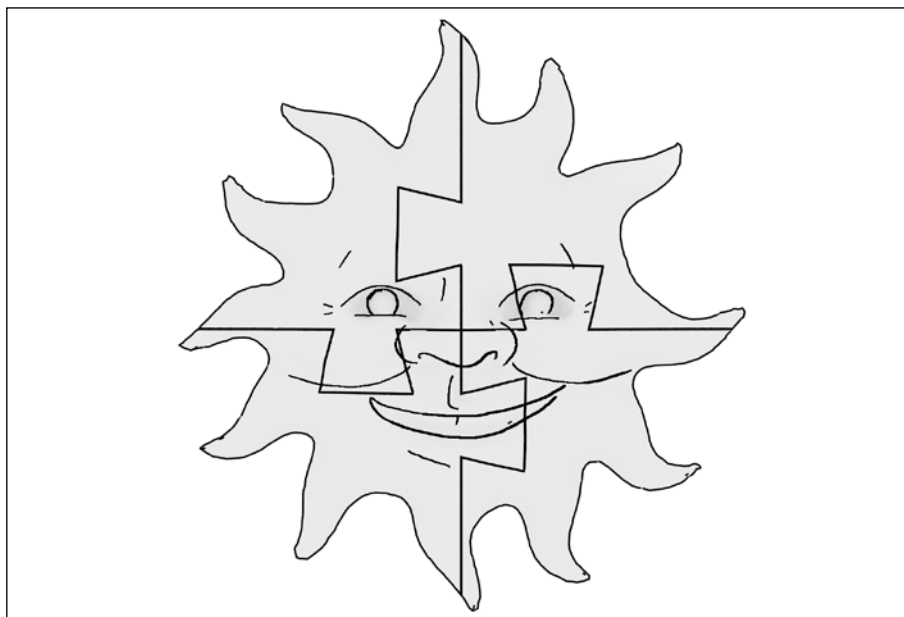

Resizing the model

While sculpting the sun face, there was very little effort made to make the model conform to a particular size. However, this is an important consideration when building the model for 3D printing because of tolerance considerations, which will be covered in more detail later.

How big should it be?

Every 3D printer has a range of print areas that it can handle. Naturally, if designing for a particular 3D printer, this should be taken into account.

For this project, the model is going to be sized so that it will be too big for any printer to print. The smallest popular 3D printer on the market has a print bed of 120 mm squared, or about 4" on each side, so that one will be what this model will be resized for.

Scaling with properties

At the end of the previous chapter, the sculpted face was left in **Object Mode**. Before continuing, make sure that the project is still in **Object Mode**, or some later steps may get confusing.

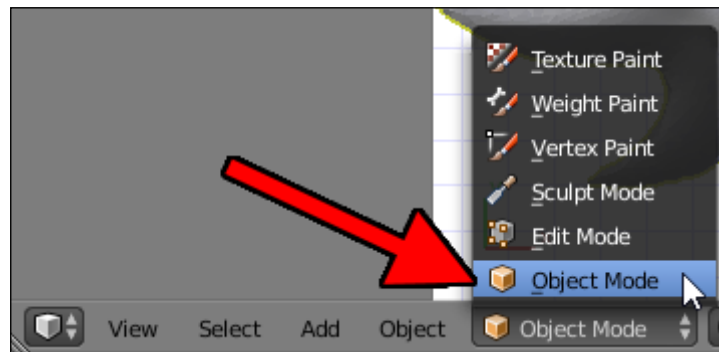

Follow these steps to scale the model:

1. In the **Properties** panel (N), to the right of the default view, locate the **Dimensions** pane:

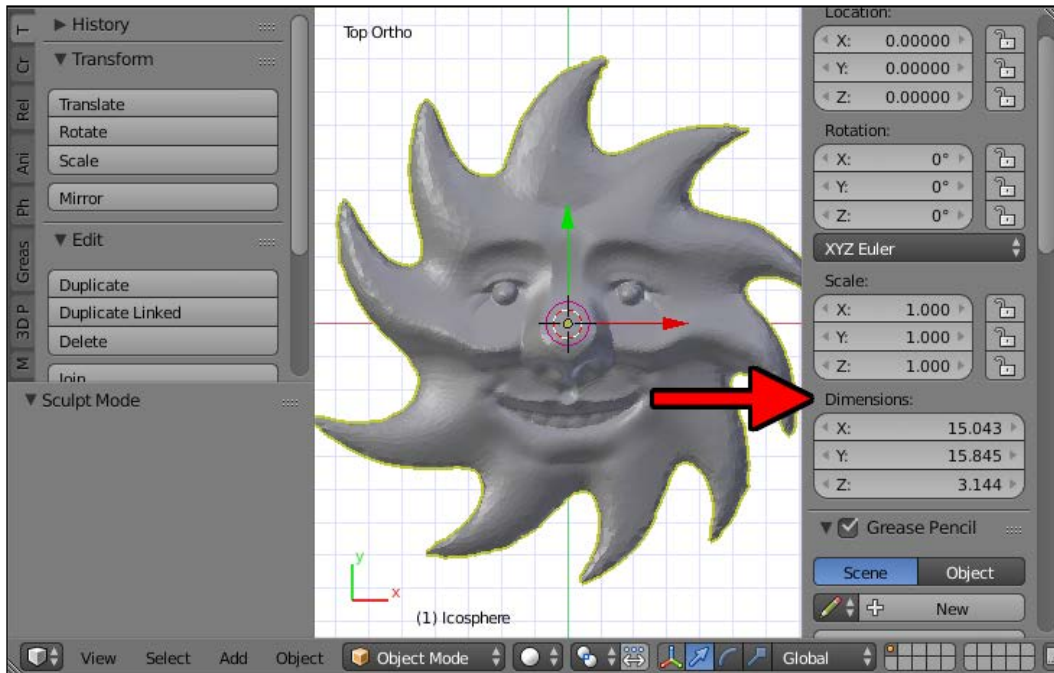

2. Change the X dimension to 100.
3. Now, locate the **Scale** setting, just above **Dimensions**, and make note of the X scale necessary to make this model 100 mm wide:

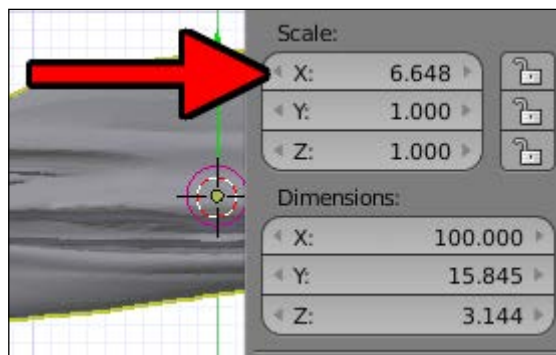

4. Round the scale value off to something easy to type (such as 6.5 in this example) and type this value in for the scale for **X**, **Y**, and **Z**:

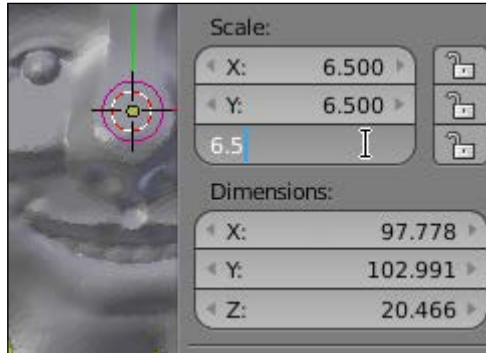

Building a puzzle piece

Now, let's build a basic puzzle piece that can be used to turn the sun into a puzzle.

Building the basic shape

Let's get started with the basic shape of a puzzle piece:

1. On the menu at the bottom of the **3D View**, locate the layers pane, which looks like an array of connected boxes. Each box is a separate layer.

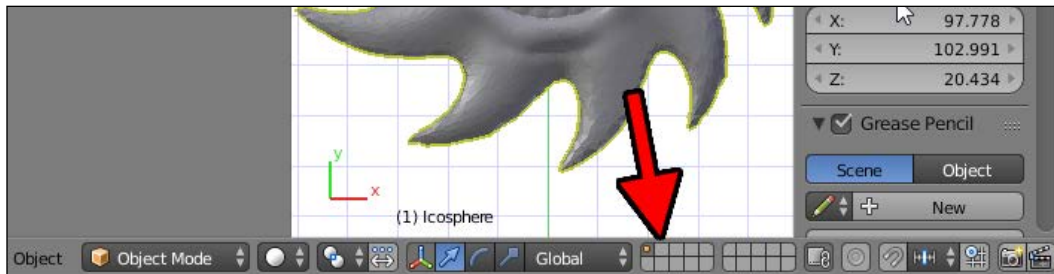

2. Click on an empty layer:

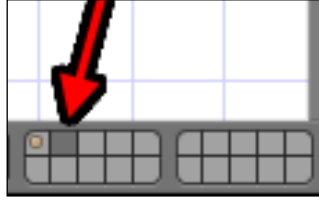

The sun will disappear, but that's simply because it's on another layer, the one with the orange dot in it. Organizing objects in different layers in Blender is a great way to ensure that things don't quickly get out of hand and to ensure that there is no need to hide or unhide individual objects. In addition, multiple layers can be viewed at once if desired, so you can work on related objects. For now, we'll use this empty layer to start building our puzzle object:

1. Add (*Shift* + *A*) a **Grid** object:

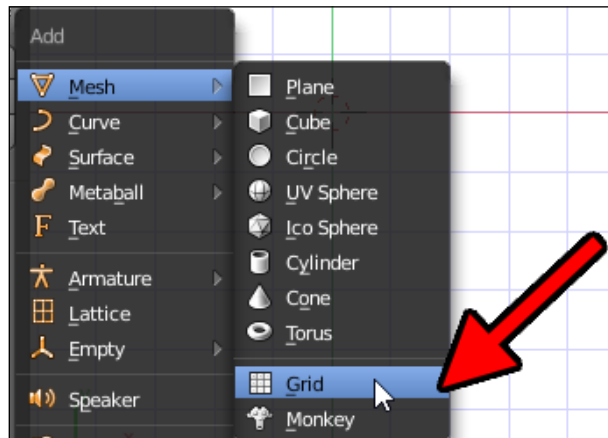

2. Under the **Tool Shelf** to the left of the **3D View** are the properties of the new **Grid**. Before clicking on anything else, change the **X Subdivisions** and **Y Subdivisions** values to 6:

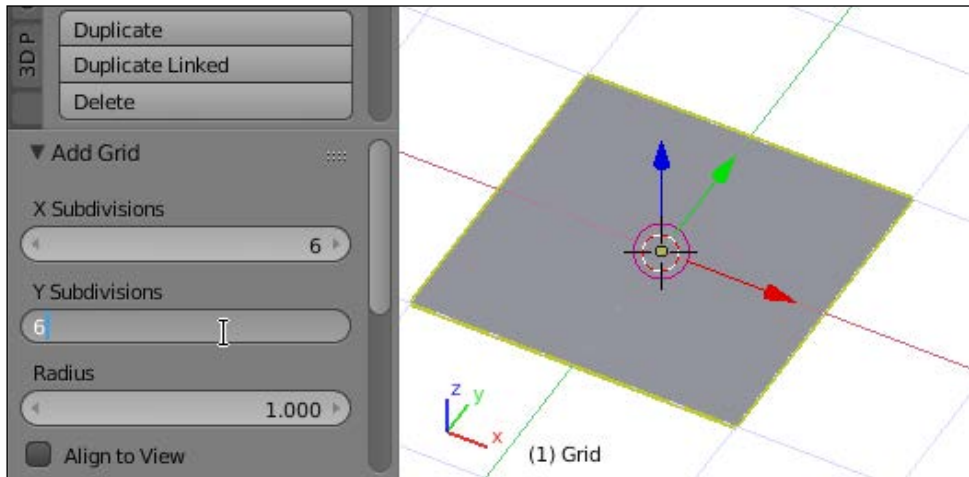

The **Grid** subdivisions won't be visible until you check its geometry by toggling **Edit Mode** quickly. For later steps, though, this piece needs to be positioned in the back-right quadrant of the 3D grid that we're working on. In other words, one corner of this grid needs to be sitting on the origin.

[ In Blender, you can transform things with exact precision by typing the number to transform it by on the keyboard while executing the command, instead of moving the mouse.]

3. Move (G) the grid along the X axis (X) 1 unit.
4. Then, move (G) the grid along the Y axis (Y) 1 unit.

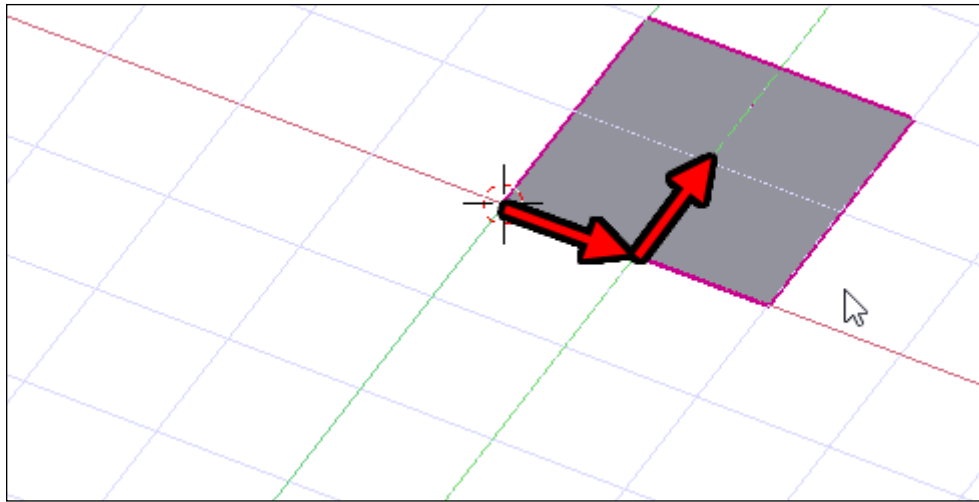

5. Enter **Edit Mode** (*Tab*) and deselect all points (*A*):

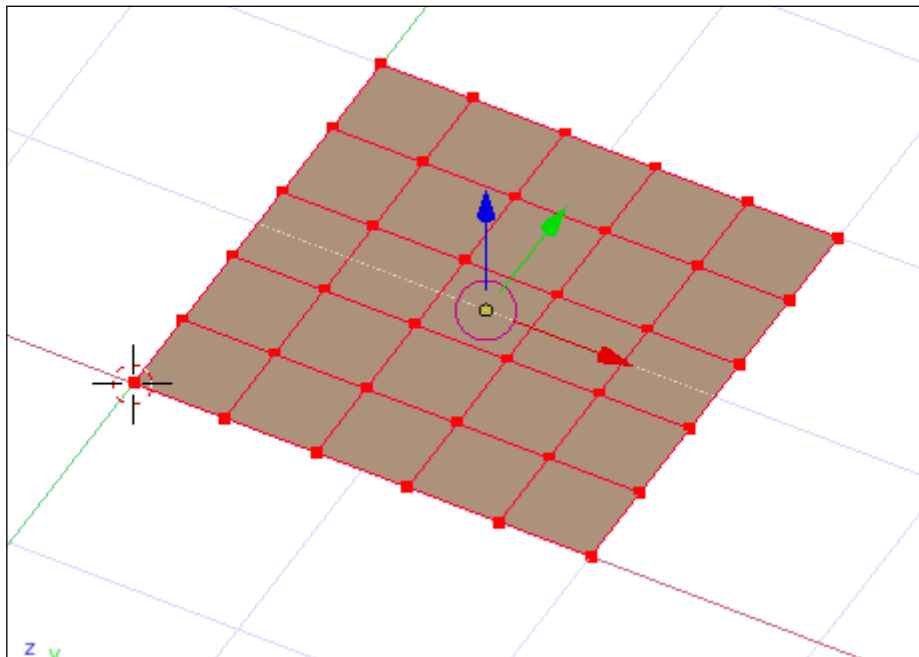

- From the origin, select the second and third vertices to the right:

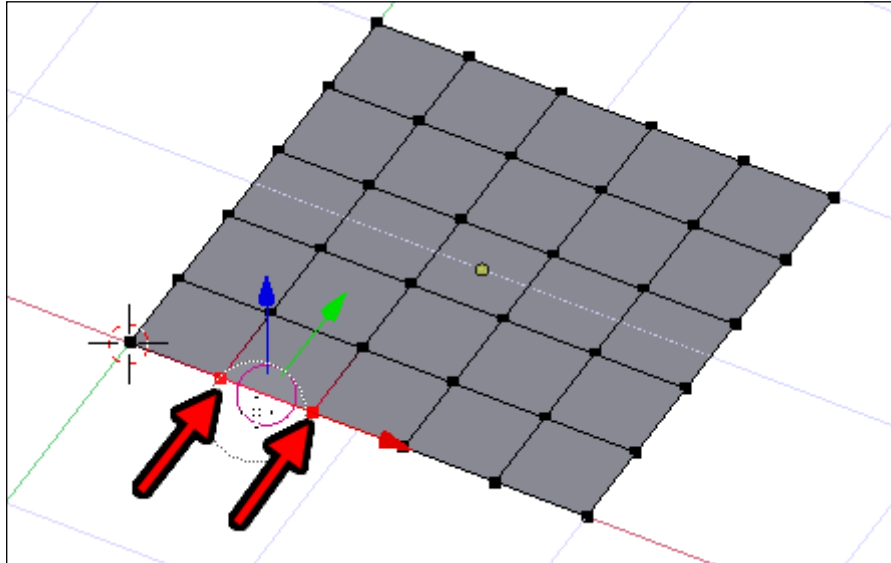

- Delete (X) the selected **Edges**:

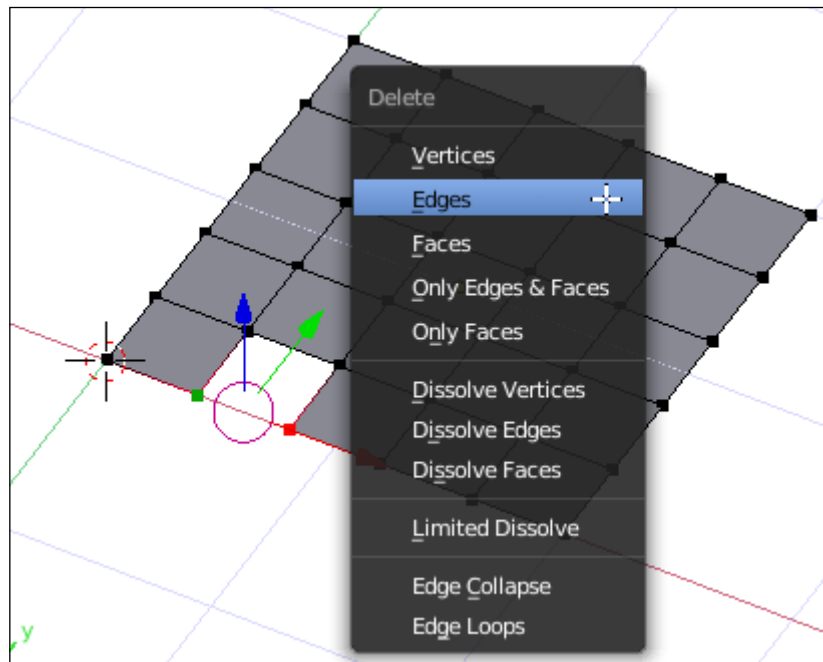

- From the origin, select the second and third vertices in the Y direction:

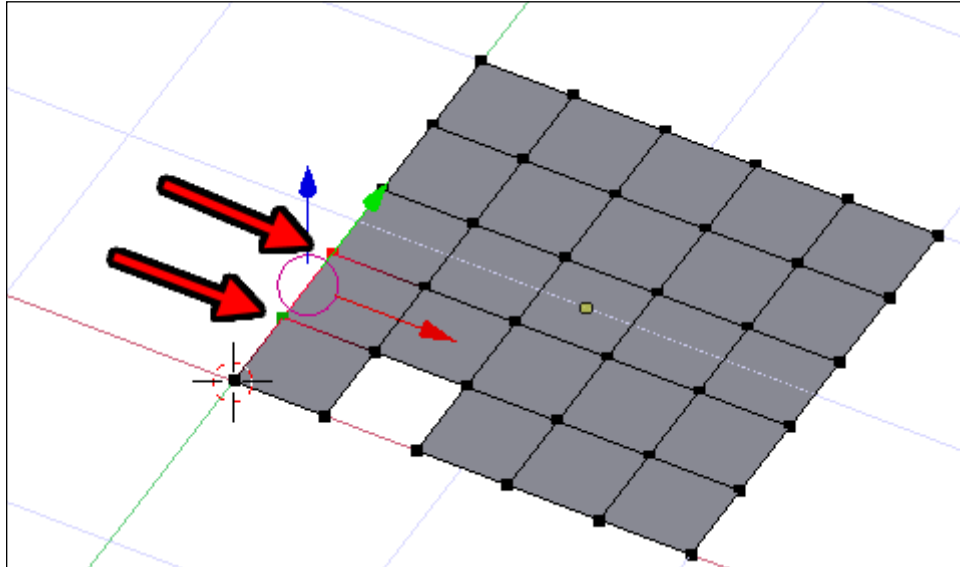

- Extrude (*E*) the selected edge -0.4 units. Be sure to type the amount to extrude on the keyboard, remembering to hit the - key when you do.

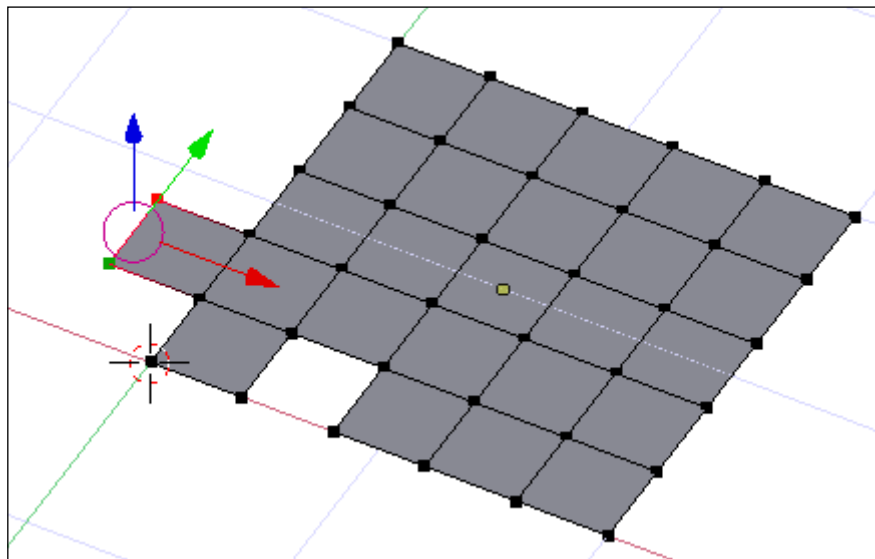

10. Scale (S) the selected edge by a factor of 1.5. Again, be sure to type the scale factor in.

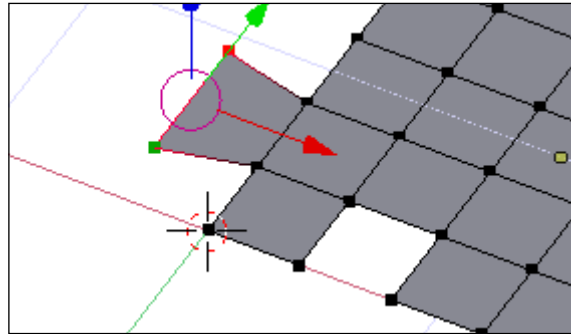

11. Select the two vertices at the top of the hole made when deleting the edge earlier:

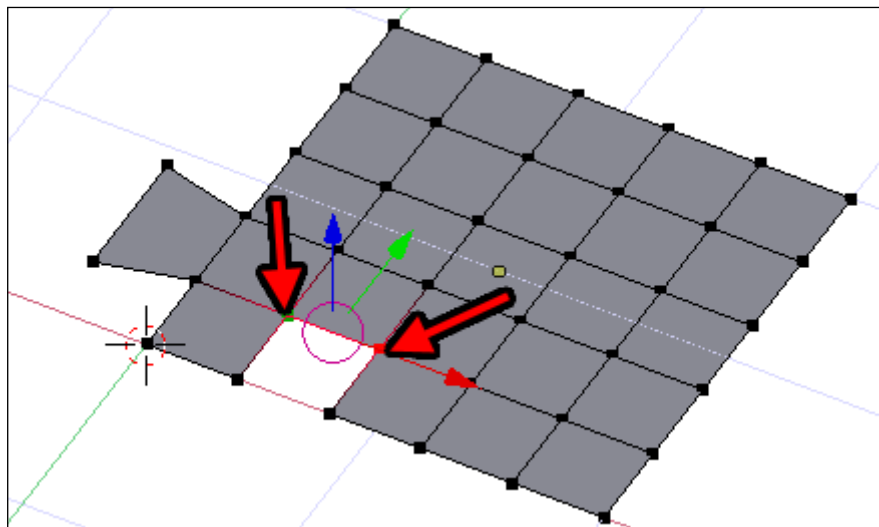

12. Scale (S) this edge by a factor of 1.5 as well:

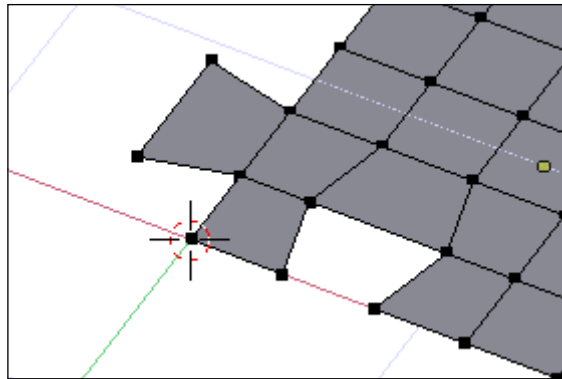

13. Leave **Edit Mode** (*Tab*).

This creates the basic, but flat, shape of an interlocking puzzle piece. Because both the tab and hole are made with complementary actions, they will mate perfectly.

Sizing the puzzle piece blank

Now to make the puzzle piece the appropriate size for the sculpted part:

1. In the menu at the bottom of the **3D View**, locate the **Pivot Center** dropdown menu, which looks like two overlapping circles by default:

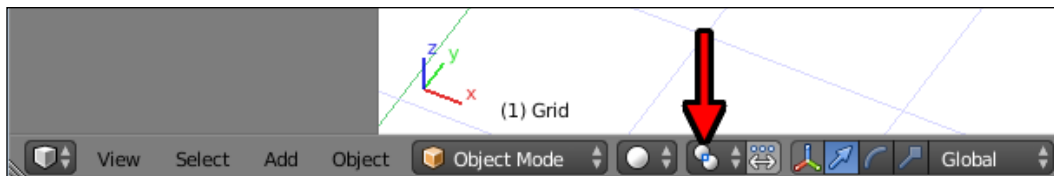

2. Click on the **Pivot Center** dropdown and select **3D Cursor**:

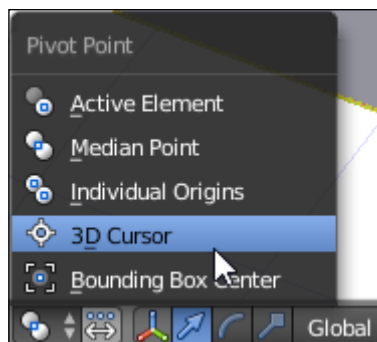

3. Be sure the **3D Cursor** is still at the origin by re-centering the view (*Shift + C*) if necessary.

 Changing the **Pivot Center** allows control of the point that the scale and rotation actions occur around. In this case, because the puzzle shape has been moved so that its corner is at the origin, the scale operation will keep that corner where it is as the rest of the piece grows. Notice how this works in the very next step.

4. Scale (*S*) the puzzle shape up some to make the next step easier.
5. With the puzzle shape still selected, hold down *Shift* and click on the layer that has the sun model in it:

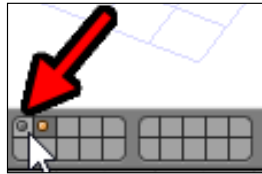

6. Scale (*S*) the puzzle up until it is bigger than the sculpted shape, along the X and Y axes:

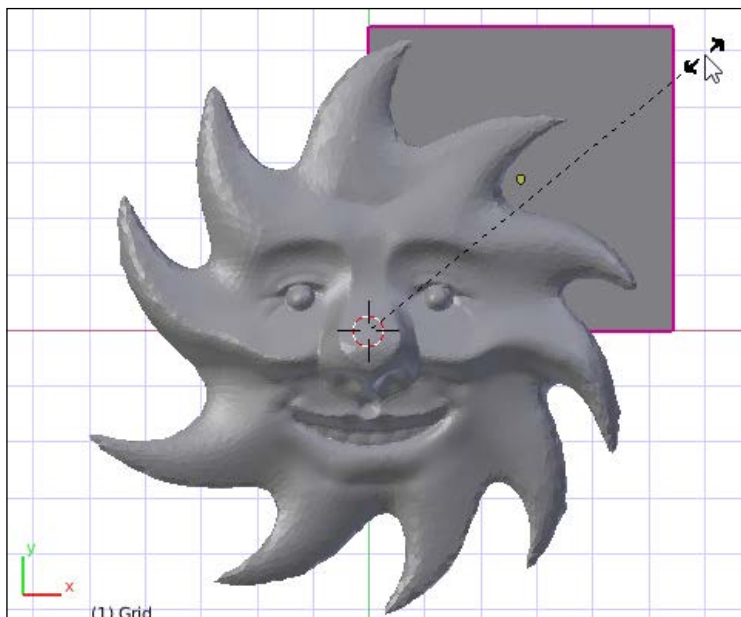

Adjusting the view and switching to **Wireframe view (Z)** can help with this step. The puzzle piece should completely cover a quarter of the sun model with the tab and blank completely inside the face without getting too close to the edge so that it can be a solid connection. If the rays of the sun reach too far to make this possible, the puzzle piece may have to be edited in **Edit Mode** to extend the edges along the X and Y axes until it fits.

7. Apply (*Ctrl + A*) the scale operation.

It is important to apply the scale operation because the modifiers we'll be using work on the object before scaling, and this project requires some precise control on the final model.

Turning a shape into an object

Let's get started with the shaping of the piece into an object:

1. With the puzzle shape selected, in the **Properties Panel**, locate and click on the **Modifiers** tab (the one that looks like a wrench):

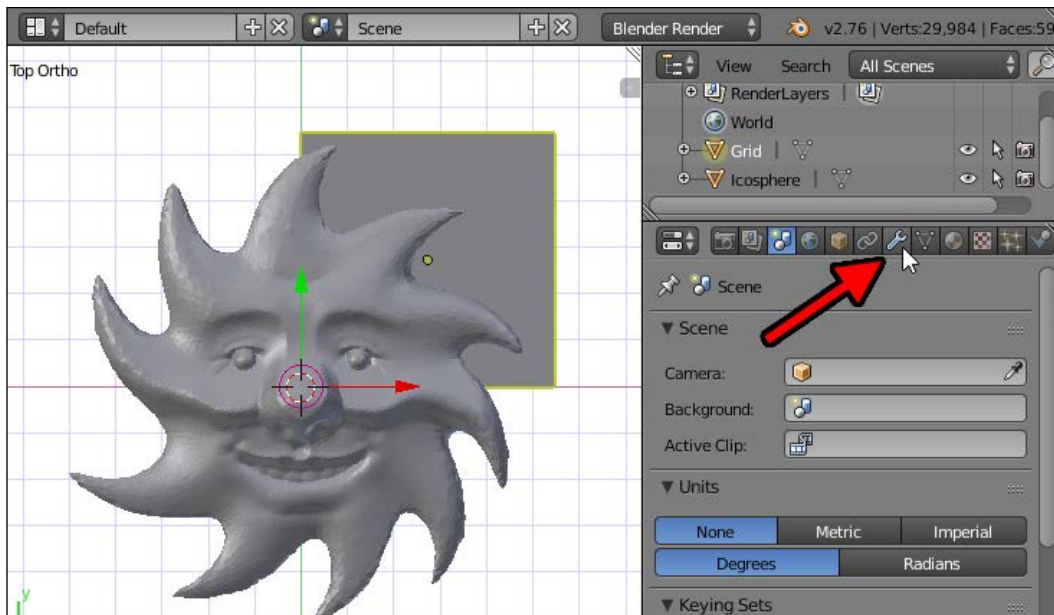

2. Click on the **Add Modifier** button and select the **Solidify** modifier:

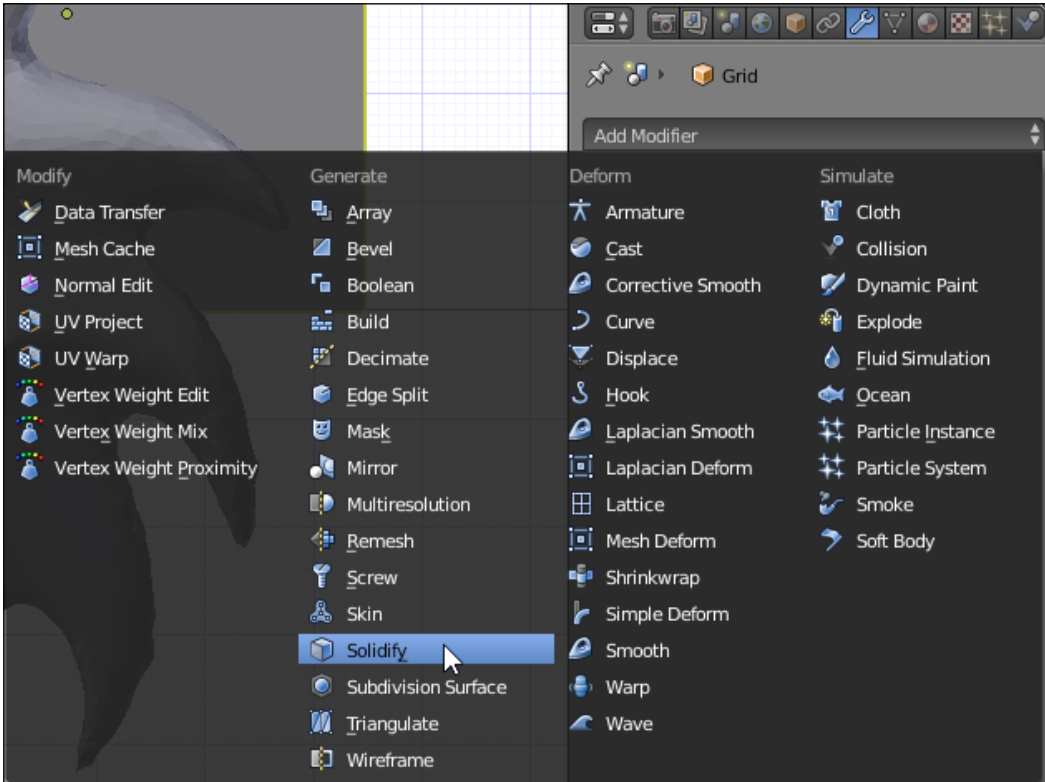

3. From the **Solidify** modifier properties, change the **Offset** value to 1.

 The **Offset** property tells the **Solidify** modifier where the newly solid shape should be created relative to the original flat shape. An offset of 0 creates a solid shape with the original shape in the exact middle. An offset of -1 makes the original shape the top of the solid shape, relative to the normal of the flat shape. An offset of 1 makes the original flat shape the bottom of the solidified shape.

4. Change the **Thickness** property to something high enough that makes the puzzle piece thicker than the sun model:

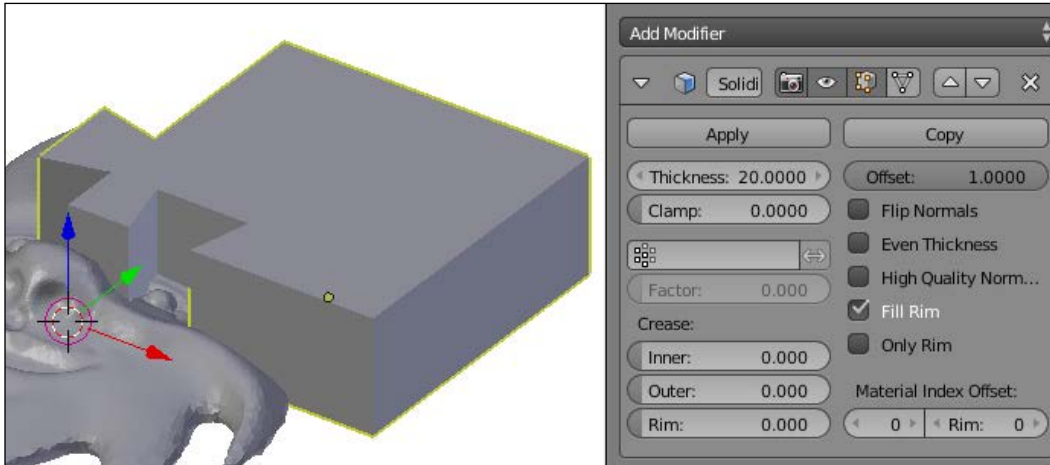

If the view is adjusted to look up from below, it can be seen that the puzzle shape, now a puzzle blank, doesn't extend to the bottom of the model. This is perfect because 3D prints need a flat bottom, and the puzzle blank will define a perfectly flat bottom, essentially cutting the bottom flat. This is nothing to worry about.

Adding some tolerance

When trying to make two objects that will interact with each other, such as the pieces of a puzzle, having pieces that are mathematically perfectly aligned is actually a bad thing. Edges in the design software that overlap perfectly will be too tight when made real to be able to slide past each other. So, the puzzle piece needs to be shrunk, just a little bit, to make it a suitable puzzle piece. Here's how you do it:

1. From the **Solidify** modifier, click on the **Apply** button:

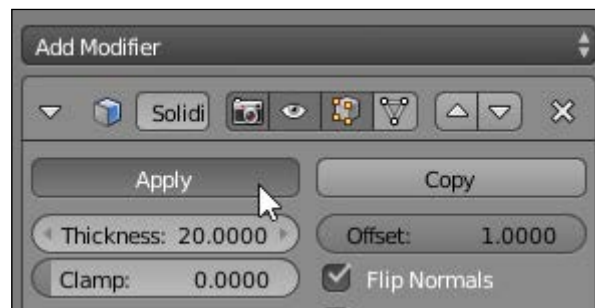

2. Click on the **Add Modifier** button and again select the **Solidify** modifier. On a flat object, the **Solidify** modifier turns it into a solid. On a 3D object, the **Solidify** modifier can be used to create a shell of controlled thickness.
3. Make sure the **Offset** value is -1.
4. Adjust the **Thickness** value to 0.2.
5. Select the checkbox options for **Even Thickness**, **High Quality Normals**, and **Flip Normals** (leave **Fill Rim** checked):

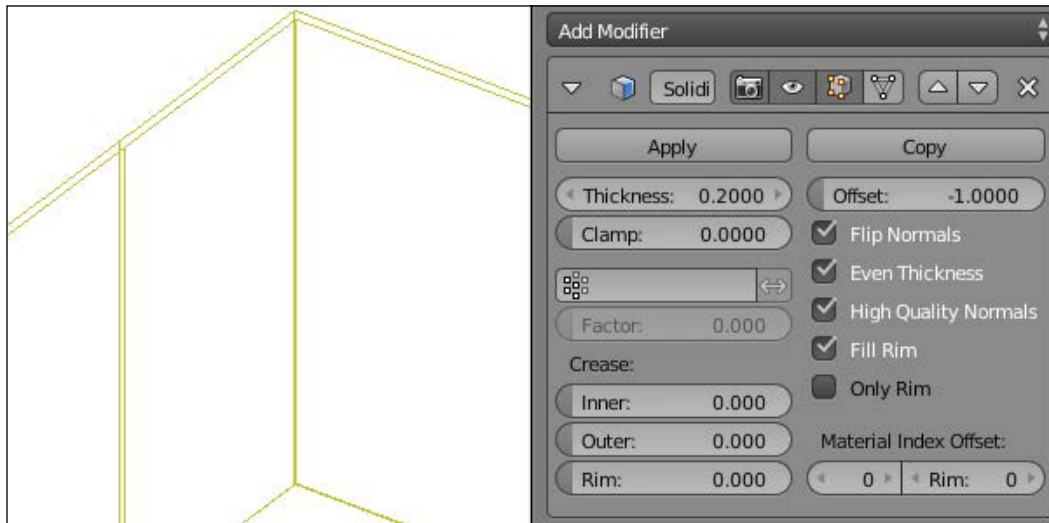

Besides the model getting darker in the **3D View**, there's no real indication of what the **Solidify** modifier did. Why did the model get darker? It is because its outside shell's normals are now pointing in the wrong direction as the **Flip Normals** option was checked. That's just a fancy way of saying that mathematically, the shape is now inside out, but that's okay because the inside-out shape is eventually going to be thrown away, with the inner shell being kept.

In **Wireframe view (Z)**, on zooming in a bit on the edge of the piece, it can be seen that inside the puzzle piece is what looks like another, slightly smaller puzzle piece.

The next step is to get rid of the old, inside-out shell and keep just the slightly smaller puzzle piece.

6. Apply the **Solidify** modifier.
7. Enter **Edit Mode (Tab)**.

- In the menu at the bottom of the **3D View**, go to **Mesh | Vertices | Separate | By loose parts**, or press *P* on the keyboard and choose **By loose parts** in the menu that pops up:

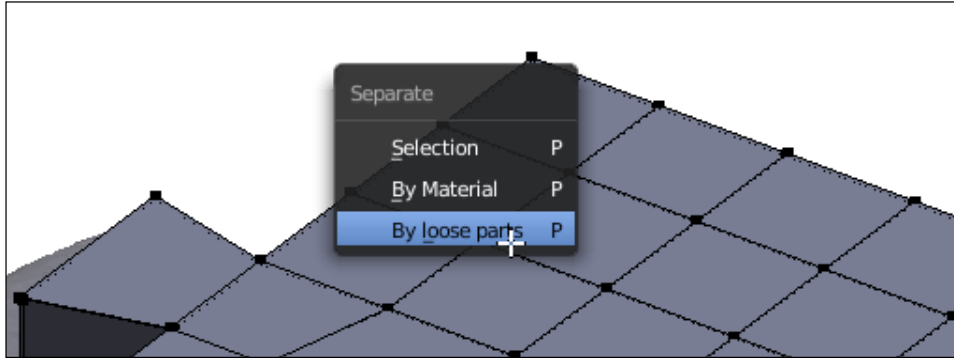

- Exit **Edit Mode** (*Tab*).

There are now two puzzle shapes, one slightly smaller than the other. This can be confirmed by looking at the outliner, like this:

- Deselect everything (*A*) and select just the outside puzzle blank.
- Delete (*X*) the outside puzzle blank, leaving just the smaller inside one. You should see something like this:

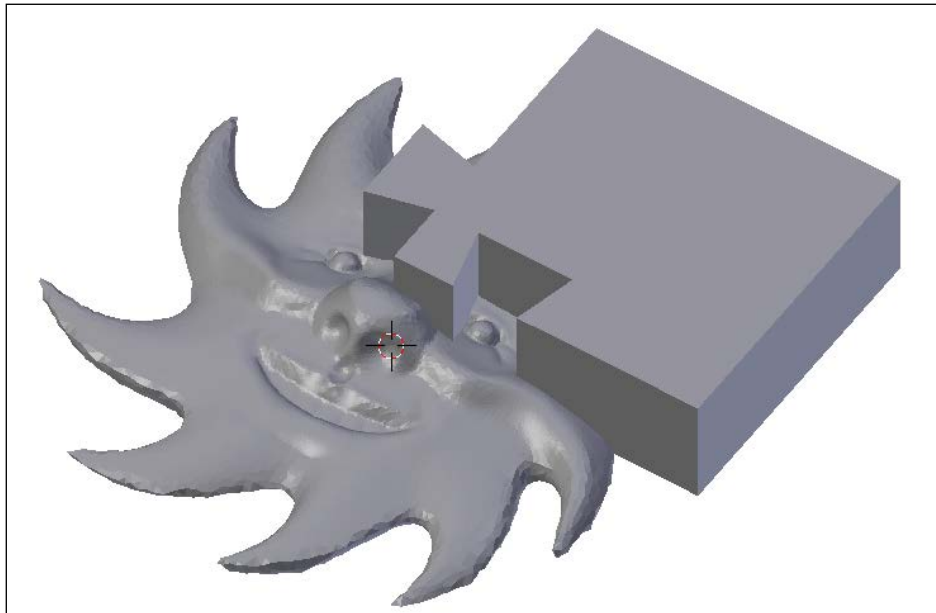

Putting it all together

We're nearing the end now. The puzzle blank has been built and been shrunk a little bit so that it works in the real world. Now to shape it like the sun model and make three more. Fortunately, this is going to be very easy:

1. Select the puzzle blank.
2. From the **Modifier** tab, click on the **Add Modifier** button.
3. Choose the **Boolean** modifier:

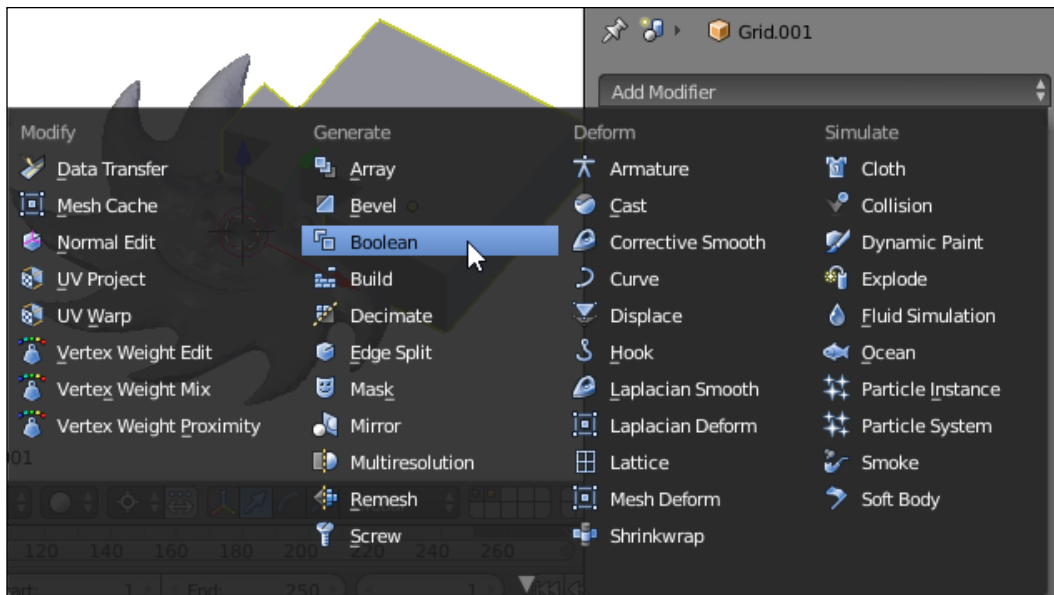

4. Be sure that the **Operation** option is set to **Intersect**.
5. Click on the **Object** dropdown and select the **Icosphere** object:



After a moment, the puzzle piece should effectively disappear. Where did it go? It's still there, but it's now shaped exactly like the part of the sun face it covered.

6. In the menu at the bottom of the **3D View**, click on just the second layer button to see the piece by itself:

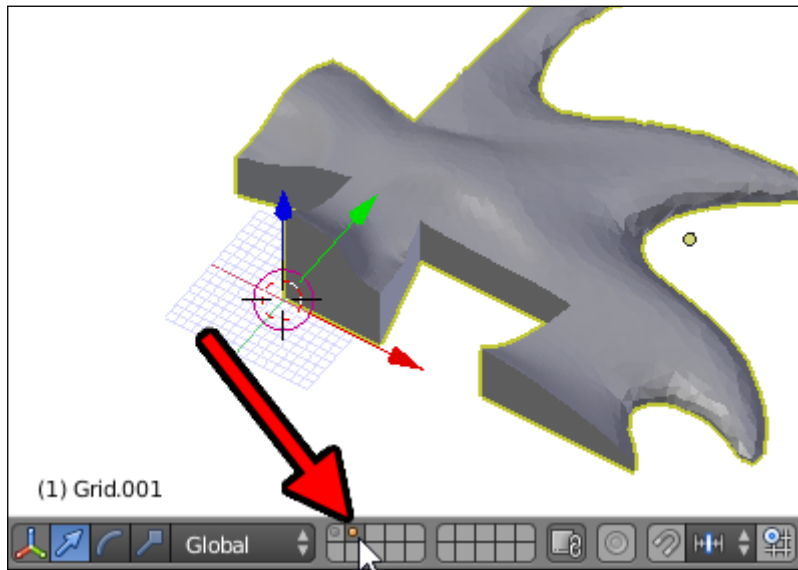

See? There it is – perfectly printable flat bottom and everything. Now, to make the other three pieces, continue with the following steps:

1. Click on the eye button in the **Boolean** modifier to temporarily disable it:

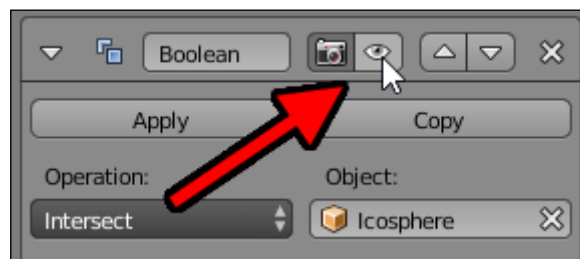

2. Duplicate (*Shift + D*) the puzzle piece and **Rotate** (*R*) it around the Z axis (*Z*) 90 degrees:

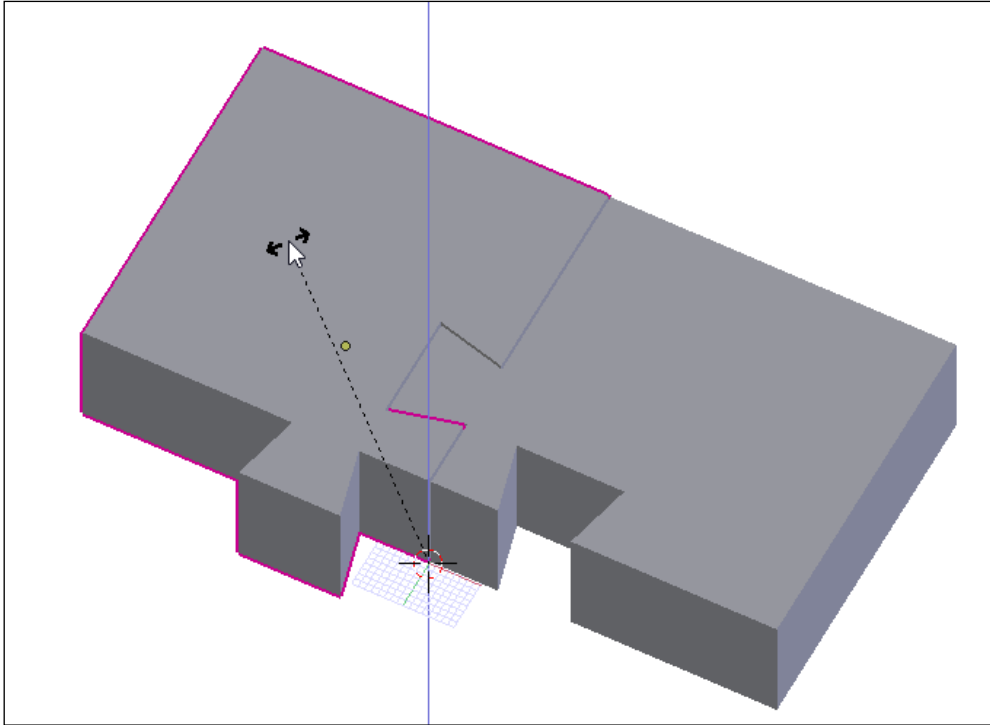

Because the **Pivot Center** was switched to the **3D Cursor** earlier, the rotation happens around the middle. Also, because the pieces were designed well, they should interlock perfectly with just a little gap between them.

If the rotation is askew, it may be because the **3D Cursor** has moved. Undo (*Ctrl + Z*) the duplication, recenter the **3D Cursor** (*Shift + C*) and try again.

3. Repeat duplicating and rotating the puzzle blank two more times:

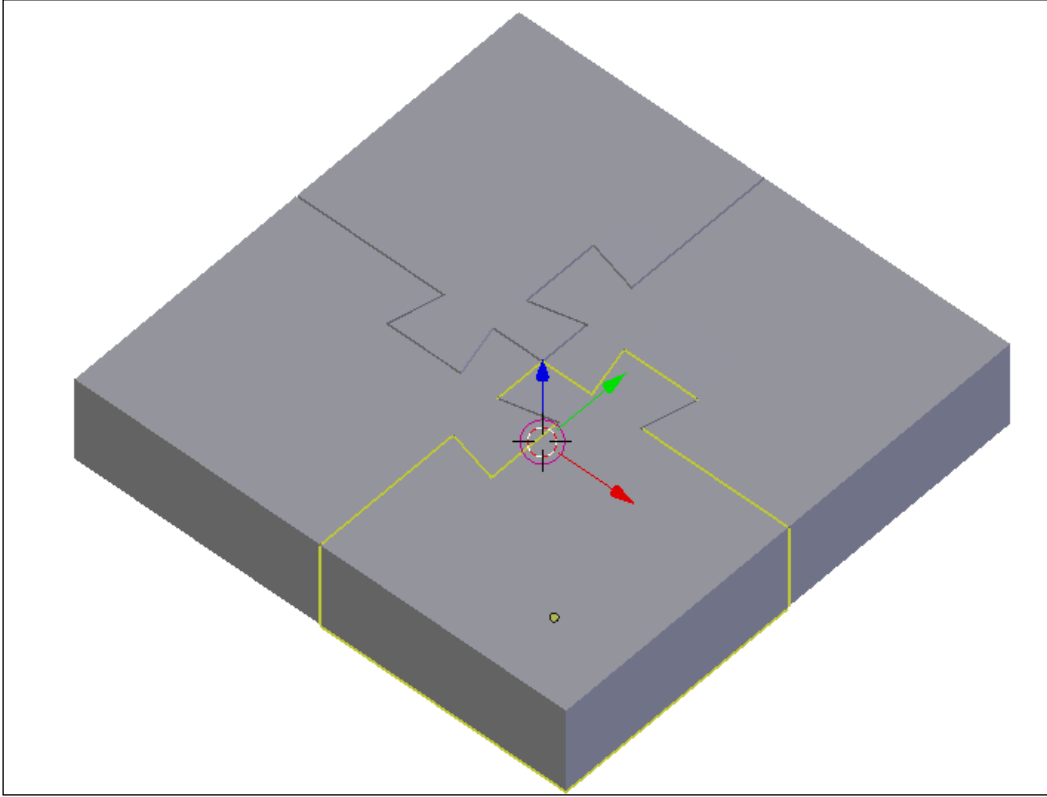

4. For each puzzle blank, click on the eye button in the **Boolean** modifier to re-enable it:

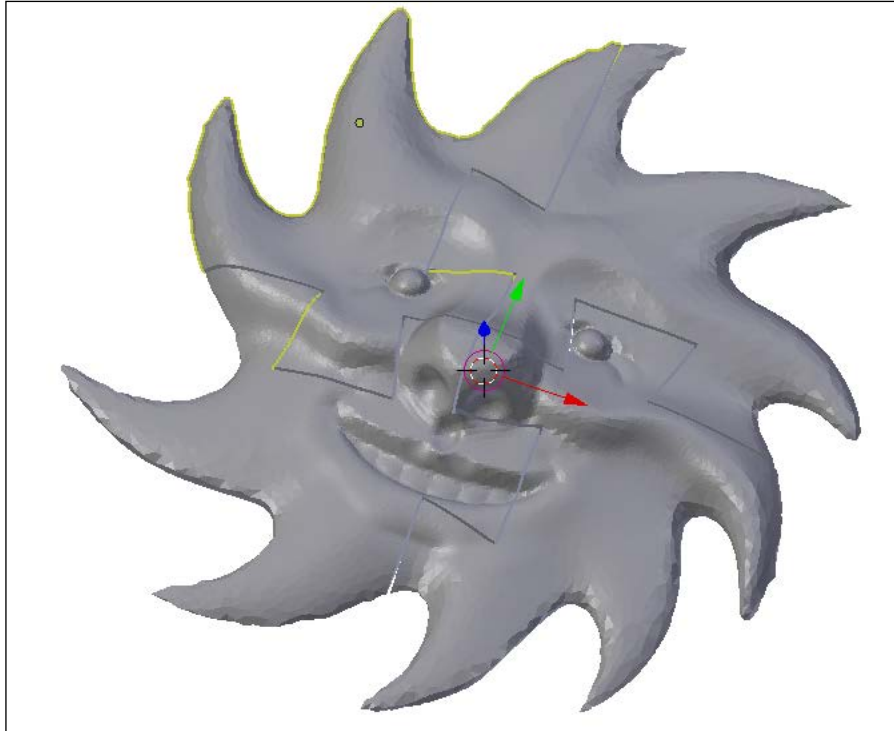

What if the Boolean modifier doesn't work?

In Blender, the complex math behind the **Boolean** modifier sometimes fails to work properly. Sometimes, it's because there are errors in the geometry of either object or the geometry is too complex. A sculpted object has very complex geometry. So, it's possible that the **Boolean** modifier doesn't perform as expected. If that happens, here's a list of things to try to fix it:

1. Apply (*Ctrl* + *A*) the rotation and scaling of both objects.
2. In **Edit Mode**, select all vertices (*A*) and **Recalculate Normals** (*Ctrl* + *N*).
3. Use the **Decimate** modifier to simplify the geometry of a complex part—in this case, the sun model. Add a **Decimate** modifier and adjust the **Ratio** down as far as it will go before a noticeable difference in the geometry of the model is seen.

4. Slightly modify the geometry of the shapes. In this case, try editing the piece blank in **Edit Mode** (*Tab*). Select all the vertices on the bottom of the puzzle piece with a **Box Select** (*B*), and **Scale** (*S*) them along the *Z* axis (*Z*) by 0 to reflaten the bottom. If this works, remember to edit the other pieces so that they all match.

Usually, one of these actions, or a combination of them, will kick the **Boolean** modifier into working, and your model will be complete.

Exporting and printing

Now that the pieces are all properly shaped, select each piece and, in the **Info** panel at the top of the screen, go to **File** | **Export** | **STL**. Give each piece a unique name, and they'll be ready for 3D printing and playing with:



Summary

In your grandparents' or parents' garage, they might have had a jigsaw and tools that they made cute wooden puzzles with—clunky shapes that vaguely resembled an elephant or truck. But nowadays, we can do so much more with 3D printing. It's not difficult to see how this project can be applied to a puzzle of any shape, just as complex or robust as a loved one's favorite thing:

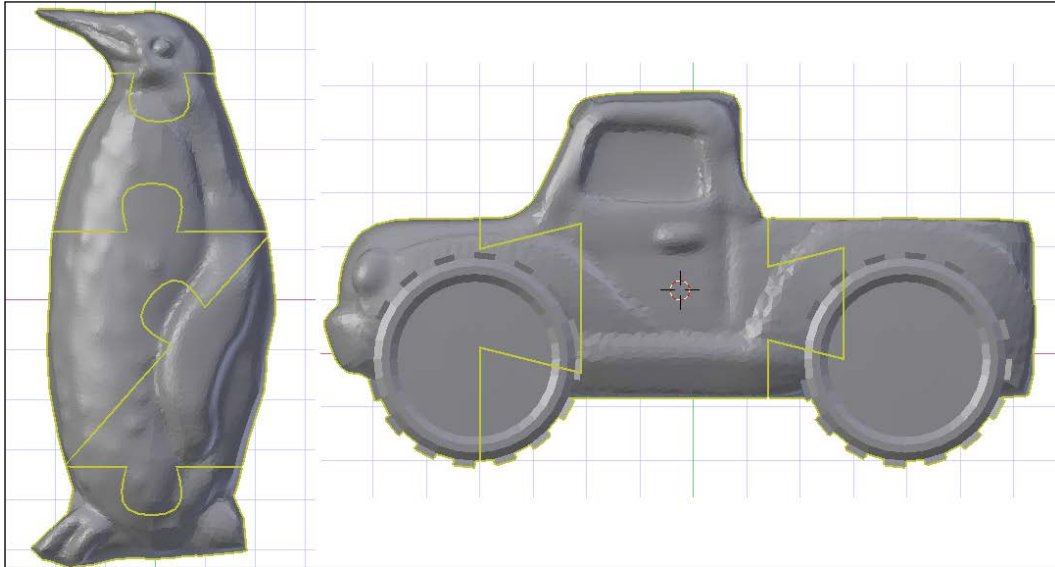

Blender's unique collection of tools seems eclectic to some, but in the end, they enable robust interactions that result in us being able to make projects such as this puzzle without having to switch tools to finish. Models can be sculpted and then, without switching tools, combined with rigid shapes to create complex but useful and fun objects for 3D printing. This project also taught you about tolerances in 3D-printed parts and how they can be adjusted to make parts that interact with each other. While different 3D printers may require different tolerances, the skills learned in this chapter can be applied to adjust those tolerances.

Index

Symbols

3D Jigsaw puzzle

- Boolean modifier, troubleshooting 98, 99
- cutting 77
- exporting 99
- implementing 94-98
- model, resizing 78
- printing 99
- properties, scaling with 78-80
- puzzle piece, building 80

3D printing

- about 1
- defining 2, 3

A

additive manufacturing 2

axis locking 30

B

Blender

- downloading 15
- installing 15
- URL 15
- using 14

Blender units

- defining 42

C

computerized numerical control (CNC) 3

D

default view, Blender

- 3D cursor 18, 19
- 3D View 17, 18
- defining 16, 17

E

Edit mode

- about 40
- object parts 41

F

face of sun, sculpting

- base object, creating 46-48
- details, sharpening 70-76
- edges, smoothing 57-59
- face, drawing 51-56
- nose and eyes, adding 60-65
- rays, pulling out 65-69
- sculpt, setting up 48-51

FFF 3D printers

- designing for 3

FFF design considerations

- about 5
- H, bridging 8
- holes, in models 10, 11
- overhangs and supports 6
- sand castle, building 6
- snowman, building 6
- supportless 3D printing 6

- T, orientation 9
- wall thickness 10
- Y, gentle overhangs 7
- FFF printers**
 - working 3, 4
- fused filament fabrication (FFF) 3**
- I**
- incremental saving**
 - defining 42
- L**
- light polymerization 3**
- O**
- object**
 - duplicating 36, 37
 - transforming 29, 30
- object selection**
 - Border select 38
 - Circle select 39
 - defining 37
 - Shift select 37
- P**
- panels**
 - 3D View 17
 - Info panel 16
 - Outliner 17
 - Properties panel 17
 - Timeline 17
- powder bed 3**
- print**
 - anatomy 4, 5
- puzzle blank**
 - implementing 94-98
- puzzle piece**
 - basic shape, building 80-86
 - building 80
 - puzzle piece blank, sizing 87-89
 - shape, turning into object 89-91
 - tolerance, adding 91, 92

- S**
- settings, Blender**
 - defining 19
 - laptop, with touch pad 22, 23
 - object creation 23, 24
 - scroll-wheel mouse and number pad 20, 21
- STereoLithography (STL)**
 - about 43
 - exporting 43
- T**
- transformations**
 - axis locking 32, 33
 - controlling 30
 - origin manipulation 35, 36
 - precise transformation 34, 35
 - view, controlling 31, 32
- V**
- view**
 - jumping, to rotation 26
 - navigating 24
 - orthographic,
 - versus perspective view 27, 28
 - panning 26, 27
 - rotating 25
 - solid view 28
 - wireframe 28
 - zooming 27

